

# Infill typologies catalogue

Revision A

Authors

Prof. Geoffrey London  
Prof. Nigel Bertram  
Oscar Sainsbury  
Tatjana Todorovic



CRC for  
Water Sensitive Cities



Australian Government  
Department of Industry, Science,  
Energy and Resources

Business  
Cooperative Research  
Centres Program



MONASH  
University

MONASH  
ART  
DESIGN &  
ARCHITECTURE



THE UNIVERSITY OF  
WESTERN  
AUSTRALIA

## **Infill typologies catalogue**

Water sensitive outcomes for infill developments (2017–2020)

*Integrated Research Project 4*

IRP4-01-2020

## **Authors**

Professor Geoffrey London<sup>1,2</sup>, Professor Nigel Bertram<sup>1,3</sup>, Oscar Sainsbury<sup>1,3</sup> and Tatjana Todorovic<sup>1,2</sup>

<sup>1</sup>Cooperative Research Centre for Water Sensitive Cities

<sup>2</sup>UWA Design School, University of Western Australia

<sup>3</sup>Monash Art Design and Architecture, Monash University

© 2020 Cooperative Research Centre for Water Sensitive Cities Ltd.

This work is copyright. Apart from any use permitted under the *Copyright Act 1968*, no part of it may be reproduced by any process without written permission from the publisher. Requests and inquiries concerning reproduction rights should be directed to the publisher.

## **Acknowledgements**

This Report was commissioned by the Cooperative Research Council for Water Sensitive Cities (CRCWSC) on behalf of the Commonwealth Government of Australia.

## **Publisher**

Cooperative Research Centre for Water Sensitive Cities

Level 1, 8 Scenic Blvd, Clayton Campus

Monash University

Clayton, VIC 3800

**p.** +61 3 9902 4985

**e.** [admin@crcwsc.org.au](mailto:admin@crcwsc.org.au)

**w.** [www.watersensitivecities.org.au](http://www.watersensitivecities.org.au)

**Date of publication:** March 2020

### **An appropriate citation for this document is:**

London, G., Bertram, N., Sainsbury, O. & Todorovic, T. (2020). *Infill typologies catalogue – Revision A*. Melbourne, Victoria: Cooperative Research Centre for Water Sensitive Cities.

## **Disclaimer**

The CRC for Water Sensitive Cities has endeavoured to ensure that all information in this publication is correct. It makes no warranty with regard to the accuracy of the information provided and will not be liable if the information is inaccurate, incomplete or out of date nor be liable for any direct or indirect damages arising from its use. The contents of this publication should not be used as a substitute for seeking independent professional advice.

# Contents

- 1.0 Introduction** **01**
  
- Water sensitive outcomes for infill development 02
- Water sensitive urban infill performance evaluation 02
- Key design principles 04
  
- 2.0 Typologies catalogue** **07**
  
- Typologies catalogue outline 08
- Category 1: Courtyard, terrace, townhouse 10
- Category 2: Stacked, cluster 30
- Category 3: 'Walk up' apartments 44
- Category 4: Mid-rise apartment buildings 54
- Category 5: Urban spaces 63
- Category 6: Precincts 71
- Case study area: Salisbury Centre East, Adelaide, SA 72
- Case study area: Knutsford Street Precinct, Fremantle, WA 80
- Category 7: Building elements 83
  
- References** **84**

# 1.0 Introduction



## Water sensitive outcomes for infill development

This catalogue was prepared as a component of the Cooperative Research Centre for Water Sensitive Cities (CRCWSC) Integrated Research Project 4 (IRP4), exploring water sensitive outcomes for residential infill developments. Its purpose is to provide evidence-based design guidelines, developed through comparative analyses, to enable better informed residential infill practice. We have prepared a range of housing typologies, at densities and configurations relevant to Australian cities and applicable to different contemporary infill development scenarios, and evaluated their water sensitive performance. 'Water sensitive' solutions are developed in an iterative process, informed by the performance evaluation of water sensitivity, thermal comfort, and architectural and urban space qualities. They are then compared with the performance of typologies currently found on the market.

Examples of design-based testing are provided in two 'case study' projects at the end of the catalogue—Salisbury Centre East in Adelaide, South Australia; and Knutsford Street Precinct in Fremantle, Western Australia. (A third case study—Norman Creek in Brisbane, Queensland—will be included in the final version of the catalogue, due to be released later in 2020.)

These case studies propose and test architectural and urban design strategies that will have an impact on water and urban thermal performance, and also on public and private amenity. Inevitably, these types and their configuration will need to be modified to fit actual sites and contexts, and to realise locally-specific opportunities.

## Water sensitive city and urban infill development

Most major cities in Australia expect intensified infill development over the coming decades (Commonwealth of Australia, 2017), which, without significant intervention, is expected to have a considerable negative influence on the hydrology, resource efficiency, liveability and amenity of our cities (Jacobson, 2011; Brunner and Cozens, 2013). The water sensitive city approach aims to support higher density communities while enhancing environmental performance (Wong and Brown, 2009). It recognises the substantial effect that intensified residential infill development has on metropolitan water performance and urban thermal comfort, given its scale and proliferation.

Medium density infill development, using efficient design strategies, presents an opportunity to transition towards water sensitive city outcomes (Newton et al., 2012; Newton and Glackin, 2014). Efficient and compact housing design can yield more outdoor space, valuable stormwater infiltration and tree canopy area. If well planned, the housing can generate higher quality outdoor space and optimise resources, eventually reducing overall water and energy demand per dwelling/person (Newton et al., 2012). In addition, climate sensitive urban design can be applied to mitigate increases in urban heat associated with higher urban density (Coutts et al., 2013; Bowler et al., 2010). However, current infill practices—in this catalogue referred to as 'business-as-usual' (BAU) infill development—demonstrate poor water and thermal performance as a result of the low site usability and overall performance (Thompson et al., 2017, pp. 177–178). Large building footprints and low-rise developments result in residual and often unusable open spaces, with inadequate tree canopy cover and cross-ventilation, and poor solar access.

This catalogue explores opportunities to improve environmental performance and liveability for higher density living. Different typological models enable high quality infill development that supports and encourages water sensitive urban intensification.

## Water sensitive urban infill performance evaluation

Water sensitive performance refers to the biophysical qualities of a water sensitive city (Wong and Brown, 2009). It also defines a set of objectives related to the protection and functionality of water in the urban landscape, such as maintaining natural hydrological flows and water use efficiency while enhancing the quality of outdoor communal and public spaces. Performance evaluation is undertaken using the Infill Performance Evaluation Framework (Renouf et al., 2019) which defines the key design parameters and generates performance indicators for a set of desired water sensitive performance criteria. The framework evaluates how urban design and building typologies perform across multiple categories covering architectural and urban space qualities, water performance and thermal comfort. It also informs the design process, and helps to generate solutions that perform well across all criteria (Figure 1 shows a potential combination of different performance criteria).

Water performance analyses aim to investigate the impact of urban development on natural hydrological flows, assessing volumes of stormwater runoff and water use efficiency. For this study, water flows for infill typologies were simulated on an annual basis using the Urban Water Mass Balance Tool (Lam et al., 2019). Using this tool, we generated performance indicators for hydrological flows and water efficiency (modelling performed by Renouf, Moravej and Lam, 2019). Good performance aims to reduce stormwater runoff by enhancing infiltration and evapotranspiration, while reducing the amount of water consumed per person to service the development.

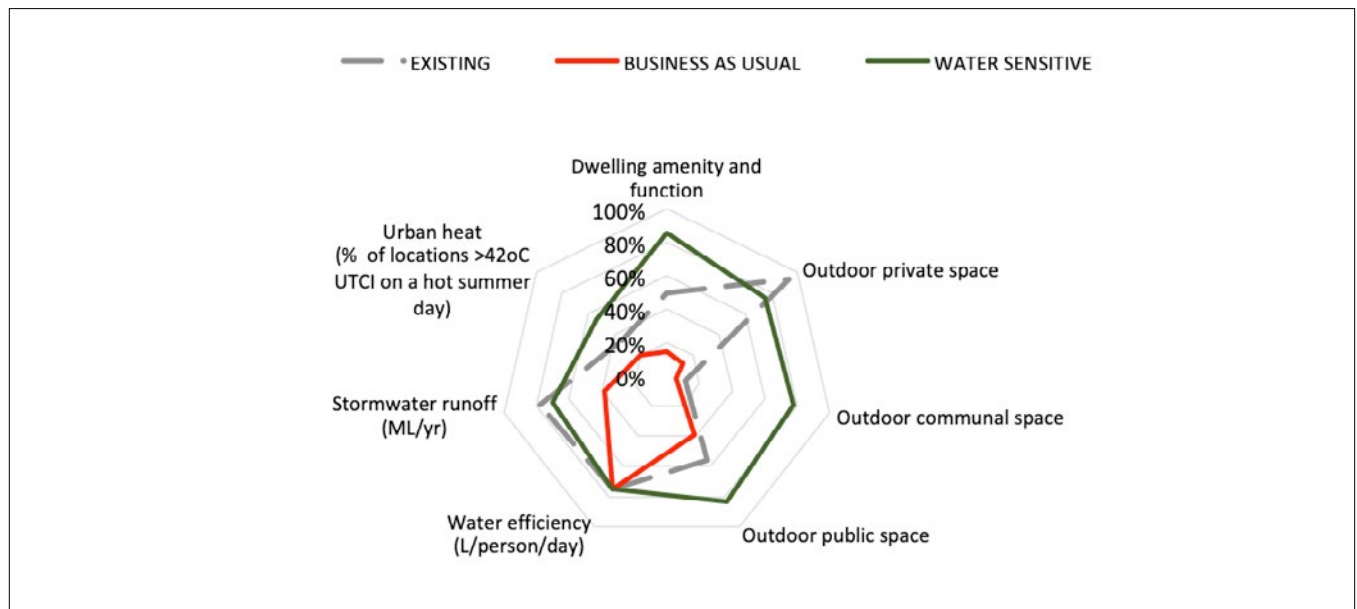

Figure 1: Multi-criteria infill performance evaluation (Renouf et al., 2019)

Proposed water sensitive infill designs involve an iterative process of design, evaluation and redesign to achieve balanced outcomes. As a result of initial analyses, the design variables that influence multiple performance objectives are observed with potential synergies and trade-offs that can work towards identifying the 'sweet spots' for dwelling design that optimise the benefits. These could include, for example:

- optimising building footprint or roof surface for runoff mitigation against rainwater harvesting
- optimising vegetated surfaces for evapotranspiration against increased water demand for irrigation
- optimising higher occupancy for water efficiency against lower occupancy from more compact dwelling size
- optimising the canopy cover, distribution and density for reduced heat stress.

As such, features supporting water efficiency and hydrological flow are crucial and represented across all categories used to evaluate architectural and urban space quality. For the reduced use of potable water for irrigation, for instance, we propose equipping dwellings with high quality water storage and recycling solutions, efficient and adaptable to the changing demands in the future. Similarly, outdoor spaces are to be treated with appropriate landscaping solutions and plants that require minimal upkeep and irrigation. Permeable surfaces allow water infiltration in places where deep soil is not attainable, such as driveways, parking, play and other recreational areas.

Available outdoor space plays an important part in both stormwater and urban heat management, creating areas suitable for large canopy trees, infiltration and permeable surfaces. But larger outdoor spaces may result in increased water and energy demand for irrigation and maintenance. One typical example is large lawn-covered outdoor areas that demand high upkeep but contribute little to reducing urban heat, especially in drier and hotter climates. Design strategies that increase usability and functionality improve the effective performance of available outdoor space. As such, thoughtful spatial organisation, with efficient and compact design features, is a key to delivering good outcomes, and is represented across all categories related to architectural and urban qualities. The design exemplars in this catalogue show both internal and external spaces that are:

- multi-functional and adaptable to different uses and living arrangements
- appropriately-proportioned, connected and positioned.

The overall quality of both indoor and outdoor spaces depends on their functionality and usability, which in turn depends on spatial organisation and design strategies that afford favourable use. Even though many aspects of the design can be quantified, analysis of urban and architectural characteristics is essentially a qualitative evaluation. As such, an 'appropriately proportioned' courtyard could be defined by the ratio of its boundary lengths, where a square-shaped space supports more diverse uses and may be deemed more functional than a long narrow courtyard. Further, an elongated space such as a linear park may be evaluated as 'appropriately proportioned' when it supports its intended uses. The next section covers the main principles and criteria used to assess quality of architectural and urban space contributing to high water and thermal performance.

# Key design principles

## 1. Access to quality outdoor public space

Under the pressures of urban intensification and demand for more compact living at higher densities, providing access to a quality public realm, such as parks, reserves and plazas, becomes essential. With more public and shared amenity, activated street frontages increase the sense of safety and neighbourliness and encourage walkability, reducing the high dependence on cars so prevalent in Australian suburbs.

Considered design strategies for residential precincts, with a range of suitable dwelling typologies allowing a diversity of household types, can complement and encourage use of nearby public open spaces. Higher densities and mixed-use typologies, with home/work options, can generate additional services and amenities over time, such as cafés, grocery shops, pharmacies and other small businesses, which increase use and passive surveillance of public spaces.

Public spaces that are designed to allow various activities maximise their use. For example, 'slow' streets can give access to residences, boost bicycle connectivity, and function as linear parks with generous tree canopy cover for communal recreational activities in a pleasant and comfortable environment at different times of the day and year.

Pedestrian- and cyclist-friendly infrastructure, including designated paths, bicycle racks, and rest and recreational areas, reduces car dependence while encouraging connectivity and use of public open spaces.

Higher performing design strategies may be included in public spaces, to allow precinct scale solutions to stormwater and urban heat reduction benefitting whole precincts and individual lots. These solutions could include a precinct scale water storage, recycling and re-use facility; and a blue-green network incorporating water elements in landscaping, such as retention ponds and green swales.

## 2. Access to quality outdoor communal space

Higher density infill development makes shared amenity a significant consideration. To increase overall site amenity and reduce individual water and energy demands necessary for upkeep, design could include shared barbeque, vegetable garden and play areas, and grouped car and bicycle parking areas.

Efficient design strategies, including compact design and organisation of buildings on site, provide quality communal spaces that are functional and accessible to all residents and adaptable to multiple uses. Certain common spaces, when well designed, can serve multiple purposes (for example, shared driveways can also be used for play and other recreational activities).

It's important to have a balanced transition between private and communal spaces, to maintain a sense of privacy and individuality and ensure adequate sound and visual barriers. Adequate setbacks, well-positioned balconies and windows, and suitable screens and fences will help minimise overlooking from more activated street frontages.

### **3. Access to quality outdoor private space**

Access to quality outdoor private space refers to providing courtyards, terraces, rooftop terraces, balconies and similar, which offer good solar access, ventilation, outlook, and sufficient soil and space for large canopy trees.

High quality outdoor private space is flexible and adaptable, designed to allow for a variety of uses. Design supports multiple use when it considers length and width, and height of surrounding walls and their effect on sun and ventilation throughout the year. Courtyards adjacent to living and dining areas may be used as an extended living room, guest entertainment area, garden, and transitional space between different house zones. An open carport may also be used as an outdoor space.

Landscaping solutions, including well-positioned large canopy shade trees, pergolas and trellises, offer shade for better thermal comfort and can provide sound and visual privacy barriers when private areas face communal and public spaces.

### **4. Dwelling amenity and function**

Water sensitive design strategies are used to deliver quality higher density living solutions, without compromising on amenity and function.

Building footprints are reduced and the number of floors increased to yield enough well-considered space for both private and communal outdoor areas on site, and allow more deep soil space to accommodate large canopy trees.

Reducing parking space from the usual two car bays to one car bay per dwelling makes available additional usable space, as does grouping parking on site. In addition, open group or individual car ports allow for permeable paving areas.

Flexibility in internal spatial arrangements is a crucial aspect of increasing usability, supporting a range of occupancies, and adapting to changing requirements over time. Flexible internal space is designed to support a diversity of uses. For example, a room with separate services adjacent to a street could be used as a home office, games room, or additional bedroom. Direct physical and visual connection to quality outdoor spaces, achieved by designing living areas adjacent to courtyards, terraces and other outdoor areas, enhances internal spatial amenity and functionality.

Position and orientation of a dwelling on the site can improve overall site usability, thermal comfort and energy efficiency. Facing windows to the north and north-east will provide favourable solar orientation, and windows in two walls of a room will allow good cross-ventilation. Adequate shading from the direct sun on the east and west sides is achieved with well-positioned greenery or shading systems. On unfavourably positioned sites, lightwells may give access to natural light and breeze.

## 2.0 Typologies Catalogue

## Typologies catalogue outline

Residential infill intensification is particularly evident in middle-ring suburbia, positioned seven to 25 kilometres away from the city centre and gravitating around existing local transport and commercial nodes (Newton et al., 2012). With increased infill activity, via lot sub-division, lot amalgamation, and greyfield and brownfield redevelopment, these formerly lower density suburbs with 10 to 15 dwellings per hectare are now reaching medium density with 40 to 60 dwellings per hectare. Dwelling typologies are planned for typical suburban allotments, distinctive for middle-ring suburbs, ranging from eight to 20 metres in width and 30 to 50 metres in depth (Murray et al., 2011). For every typological category, this catalogue adopts and tests allotment size based on a selected existing suburban development.

Each catalogue entry presents context and floor plans, sections and isometric views, followed by data boxes that include information about occupancy and density rates, water storage capacity, and other data. Diagrams illustrate important spatial information found in the databoxes—for instance, types of outdoor surface, and available area for large canopy trees—represented in different colours and symbols. Diagrams show spatial organisation and function of both indoor and outdoor spaces, and their accessibility and connection, which are used to evaluate qualitative urban and architectural elements relevant for water and thermal performance.

To enable comparative performance analyses, and to better understand water sensitive design features and performances, this catalogue presents and tests three scenarios for each typological category:

- Existing suburban condition, pre-infill development
- Business-as-usual infill development
- Water sensitive infill development.

An existing suburban scenario shows a typical development found in middle-ring suburbs, presuming no changes to pre-infill suburban allotment and design. Most commonly this is a single dwelling, detached, one to two storeys high, situated on a single suburban lot. Such houses are characterised by generous private space (both indoor and outdoor) capable of achieving desirable solar access and cross-ventilation, and mature tree canopy.

The existing scenario for low-rise apartment buildings and walk ups, shows constructions that are two to three storeys high, with a large building footprint and remaining outdoor space typically reserved for access and parking.

The business-as-usual infill scenarios are typically developed as one to three constructions on a single sub-divided lot, or as a group of four to eight units on two adjoining lots, achieving higher density than existing suburban developments. Dwellings are usually detached or semi-detached one and two storey houses, duplex houses, dual occupancy or terrace houses, or low-rise apartment developments. A duplex house sits on a sub-divided single lot with a separate title and clearly defined individual lot boundaries for each dwelling, while dual occupancy dwellings share the same title. A duplex house is more commonly a semi-detached house, sharing a boundary wall with the neighbouring dwelling, but with separate access and private outdoor areas. Typically, business-as-usual infill developments have large building footprints and driveways, leaving little or no outdoor space for permeable surfaces, vegetation and large canopy trees. Lack of quality outdoor space affects a dwelling's amenity and function, with poor solar access and cross-ventilation increasing the need for air conditioning.

The water sensitive infill scenario offers alternative design strategies to the business-as-usual practice, particularly in terms of compactness and available outdoor spaces on site. Developed designs propose increased height, with houses ranging from two to three floors, and unit constructions from three to five floors. With grouped housing projects, stacked or clustered, proposed for consolidated lots rather than single lots, there is more capacity to plan and incorporate water sensitive design solutions.

In the catalogue, infill typologies are categorised according to the infill dwelling type and scale, ranging from small scale infill developments on a single or double lot, over medium scale developments on amalgamated lots, to larger precinct scale developments. The scale and type of development will impact the internal organisation and function, and the type, size and quality of outdoor space. Developments on consolidated sites and precincts are an opportunity to use communal and public outdoor spaces.

The catalogue nominates three categories of scale of project and related outdoor space:

**i – Small scale infill developments with groups of two to six dwellings and some communal outdoor space**

Smaller scale infill developments are typically two to three dwellings on a single allotment, or four to six on two adjoining lots, achieving densities of 30 to 50 dwellings per hectare. Dwellings share boundary walls on one or more sides, and are usually two to three storeys high. Performance assessment is done on a single lot or two adjoining lots; the quality of private outdoor spaces and the compactness and efficiency of indoor spaces are dominant attributes in determining the effectiveness of water sensitive design strategies. Communal outdoor space in these typologies is minimal, reserved for shared driveway and occasionally for parking areas. The performance of individual lots is potentially complemented with good close-by quality public outdoor space, in which case good connection and access to public outdoor space becomes an important feature.

Category 1: Courtyard, terrace, townhouse

**ii – Medium scale infill developments, from six to 20 units, with significant communal outdoor space**

Typologies under this group refer to medium scale infill developments in which strata-titled dwellings, houses, units or apartments are stacked or clustered on two or more consolidated lots. Groups of dwellings are typically planned as one development, which presents an opportunity to apply efficient design strategies for more effective use of outdoor spaces. For these categories, communal or shared outdoor space becomes a dominant feature. When compared with the previous category, each individual unit still contains private space, but communal or shared spaces are larger and better proportioned to accommodate multiple uses and design options. A range of communal

outdoor spaces is possible, such as grouped parking. Again, proximity and balanced connection to good quality outdoor public space could add to the analysed site's performance. Private outdoor space, on the ground or on the roof or balconies, and the functionality of its layout is relevant for water performance, especially in terms of establishing good connection and balanced transition between private, communal and public spaces.

Category 2: Stacked, cluster

Category 3: 'Walk up' apartments

Category 4: Mid-rise apartment buildings

**iii – Large scale infill developments, more than 20 dwellings, significant communal and public outdoor space**

Large block or precinct scale infill developments are generally a combination of several infill dwelling typologies and urban space types. For performance analyses, the emphasis is on quality and access to outdoor spaces; in particular, communal and public open spaces resulting in modified streets, parks and plazas. Dwelling amenity and function remain relevant to these categories, especially in terms of the dwelling orientation and connection to well-designed outdoor spaces.

Category 5: Urban spaces

Category 6: Precincts



## Category 1: Courtyard, terrace, townhouse

This category refers to a multiple dwelling infill type, usually developed as two to three houses on a single sub-divided suburban lot, or four to six dwellings on two adjoining lots. This type of dwelling shares boundary walls on two sides, except for the corner dwelling, and forms a row of houses. Private outdoor spaces, front yard and back yard, or courtyards, balconies, terraces and rooftop terraces, provide access to sun and vegetation, and enable cross-ventilation. A variation of a townhouse type—a shophouse dwelling—can support mixed-use infill developments, especially if situated close to a neighbourhood transportation and commercial node. Characteristic of this model is a mixed-use ground floor, for home office or retail, facing the main street, and living areas situated either in the back towards the central courtyard or on the first floor. Shophouses are generally positioned closer to the street, with minimal setbacks, providing more opportunities to activate street frontage.

**Category 1:**  
**Courtyard, Terrace, Townhouse**  
 Existing Suburban Condition  
 Single Detached House

- permeable surface - people
- permeable surface - car
- non-permeable surface
- non-permeable surface - usable
- deck / terrace
- garden
- garden - usable
- tree
- deep root zone
- capture
- store
- infiltrate (full)
- infiltrate (partial)



context plan 1/1000

<b>Site Data:</b>			
Site Area:	1420 m2 (2 lots)	Permeable Hard Surface:	0 m2
Number of Lots:	2	Non Permeable Hard Surface:	276 m2
Number of Dwellings:	2	Vegetated Surface:	844 m2
Density:	14 dwellings per hectare	Deep Root Zones:	4 (703 m2)
Open Space:	1160 m2	Canopy Trees	6+
Site Coverage:	18%	Additional On-Site Water Storage:	None

**Category 1:**  
**Courtyard, Terrace, Townhouse**  
 Existing Suburban Condition  
 Single Detached House

- permeable surface - people
- permeable surface - car
- non-permeable surface
- non-permeable surface - usable
- deck / terrace
- garden
- garden - usable
- tree
- deep root zone
- capture
- store
- infiltrate (full)
- infiltrate (partial)

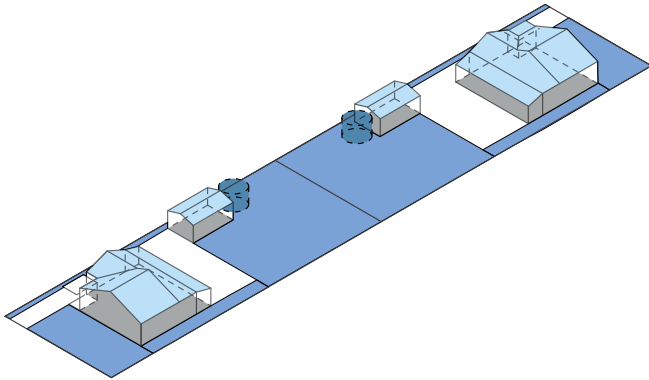

**axo (water)**

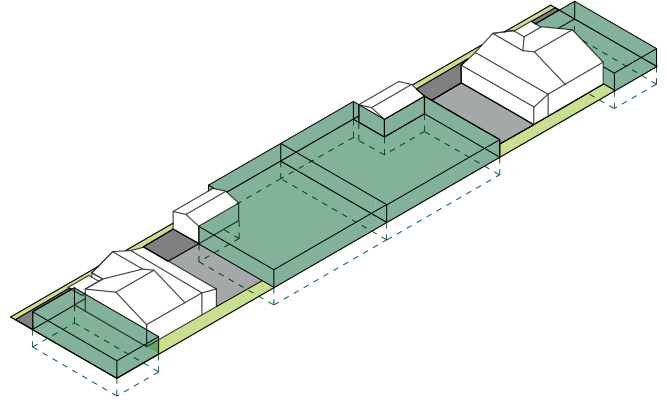

**axo (landscape)**

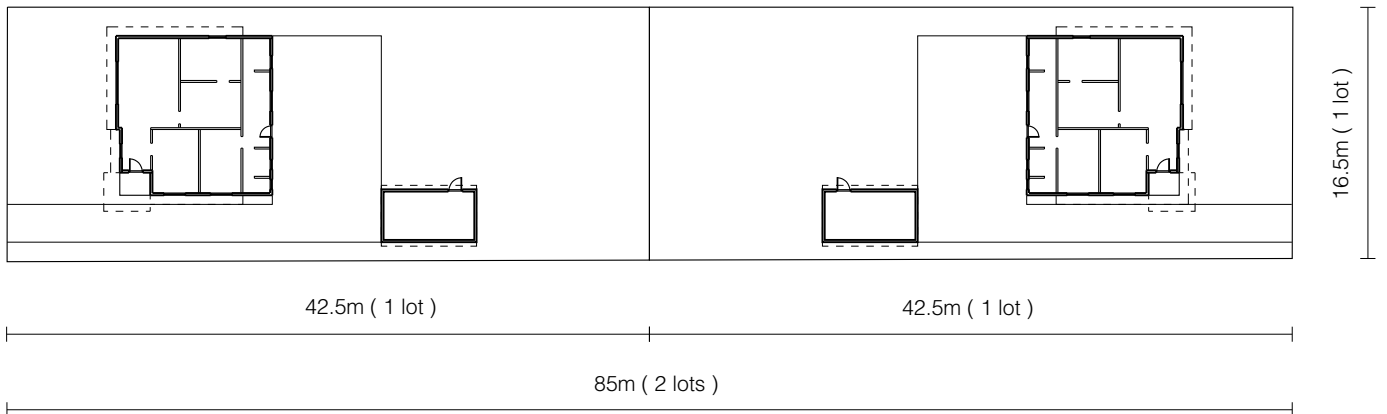

**plan 1 / 500**

<b>Dwelling Data:</b>			
Bedrooms:	3 (per dwelling)	Floor Area (deck):	0 m2
Occupants:	4 to 6 (per dwelling)	Garden Area:	422 m2 (per dwelling)
Cars:	2+ (per dwelling)	Roof Surface Area:	150 m2 (per dwelling)
Building Storeys:	1	% of roof area connected to rainwater storage:	16%
Building Footprint:	120 m2 (per dwelling & garage)	Rainwater Storage Capacity:	2500L (per dwelling)
Floor Area (building):	120 m2 (per dwelling & garage)	Household water appliances: (per dwelling)	1x shower, basin, wc, bath, kitch sink, laun tub, wm.

**Category 1:**  
**Courtyard, Terrace, Townhouse**  
 Standard Industry Practice  
 Two Unit Occupancy

- permeable surface - people
- permeable surface - car
- non-permeable surface
- non-permeable surface - usable
- deck / terrace
- garden
- garden - usable
- tree
- deep root zone
- capture
- store
- infiltrate (full)
- infiltrate (partial)



context plan 1/1000



Site Data			
Site Area:	1420 m2 (2 lots)	Permeable Hard Surface:	0 m2
Number of Lots:	2	Non Permeable Hard Surface:	379 m2
Number of Dwellings:	4	Vegetated Surface:	304 m2
Density:	28 dwellings per hectare	Deep Root Zones:	2
Open Space:	770 m2	Canopy Trees	2
Site Coverage:	46%	Additional On-Site Water Storage:	None

**Category 1:**  
**Courtyard, Terrace, Townhouse**  
 Standard Industry Practice  
 Two Unit Occupancy

- permeable surface - people
- permeable surface - car
- non-permeable surface
- non-permeable surface - usable
- deck / terrace
- garden
- garden - usable
- tree
- deep root zone
- capture
- store
- infiltrate (full)
- infiltrate (partial)

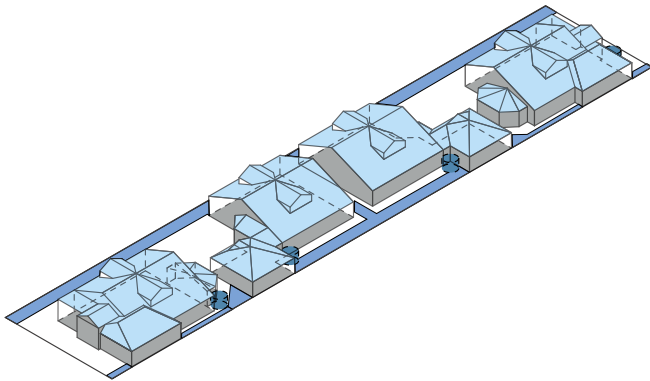

**axo (water)**

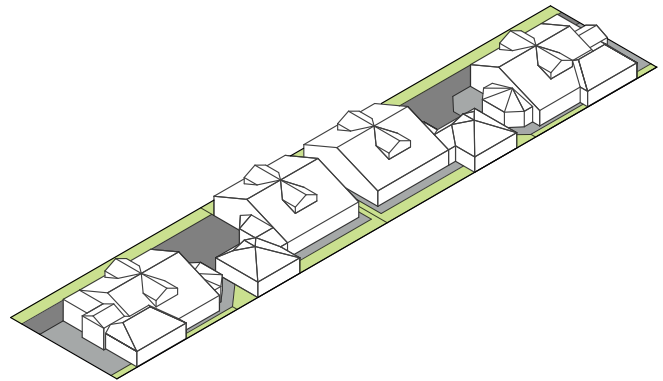

**axo (landscape)**

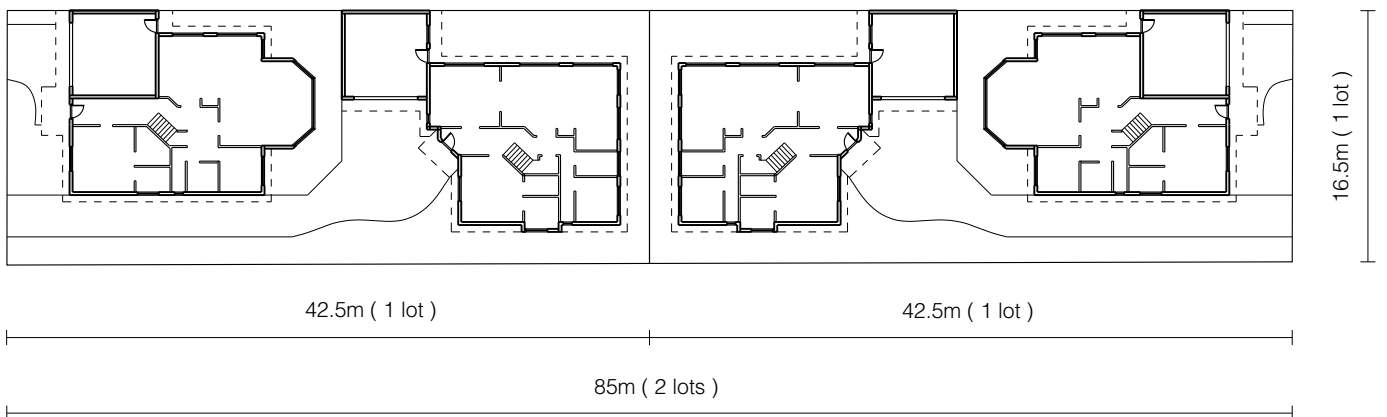

**plan 1 / 500**

<b>Dwelling Data:</b>			
Bedrooms:	3 (per dwelling)	Floor Area (deck):	0 m2
Occupants:	4 to 5 (per dwelling)	Garden Area:	76 m2 (per dwelling)
Cars:	2 (per dwelling)	Roof Surface Area:	188 m2 (per dwelling & garage)
Building Storeys:	2	% of roof area connected to rainwater storage:	40%
Building Footprint:	162m2 (per dwelling & garage)	Rainwater Storage Capacity:	1000L (per dwelling)
Floor Area (building):	200m2 (per dwelling & garage)	Household water appliances: (per dwelling)	2x shwr, basin, wc, 1x bath, kitch sink, laun tub, wm.

**Category 1:**  
**Courtyard, Terrace, Townhouse**  
 Water Sensitive Design  
 Infill Opportunities, Monash University  
 2012

- permeable surface - people
- permeable surface - car
- non-permeable surface
- non-permeable surface - usable
- deck / terrace
- garden
- garden - usable
- tree
- deep root zone
- capture
- store
- infiltrate (full)
- infiltrate (partial)



context plan 1/1000



Site Data			
Site Area:	1420 m2	Permeable Hard Surface:	539 m2
Number of Lots:	2	Non Permeable Hard Surface:	0 m2
Number of Dwellings:	6	Vegetated Surface:	532 m2
Density:	42 dwellings per hectare	Deep Root Zones:	8 (430 m2)
Open Space:	1090 m2	Canopy Trees	10+
Site Coverage:	23%	Additional On-Site Water Storage:	Communal water tanks

**Category 1:**  
**Courtyard, Terrace, Townhouse**  
 Water Sensitive Design  
 Infill Opportunities, Monash University  
 2012

- permeable surface - people
- permeable surface - car
- non-permeable surface
- non-permeable surface - usable
- deck / terrace
- garden
- garden - usable
- tree
- deep root zone
- capture
- store
- infiltrate (full)
- infiltrate (partial)

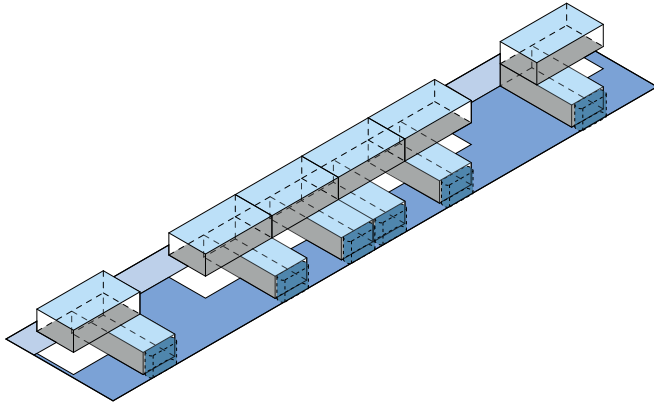

**axo (water)**

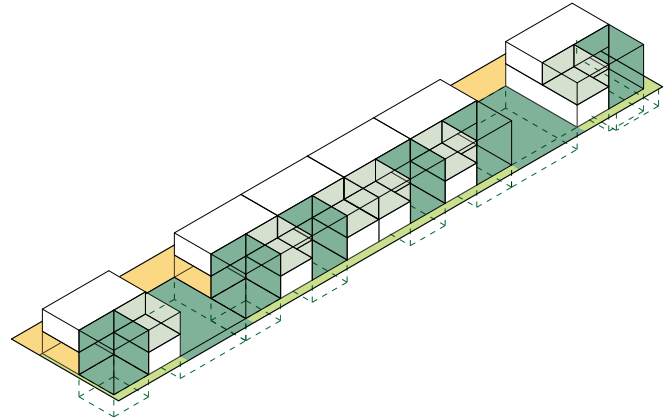

**axo (landscape)**

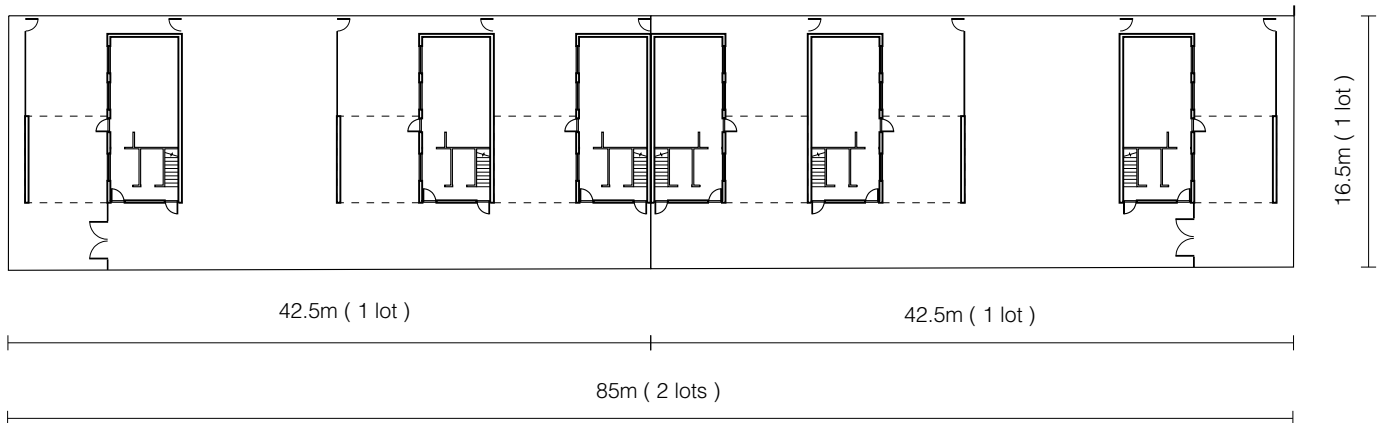

**plan 1 / 500**

<b>Dwelling Data:</b>			
Bedrooms:	2 and 3 (per dwelling)	Floor Area (deck):	30 m2 (per dwelling)
Occupants:	2 to 5 (per dwelling)	Garden Area:	42 m2 (private) + 46 m2 (communal) (per dwelling)
Cars:	2 (per dwelling)	Roof Surface Area:	55 m2 (per dwelling)
Building Storeys:	2 (3)	% of roof area connected to rainwater storage:	100%
Building Footprint:	55 m2 (per dwelling)	Rainwater Storage Capacity:	5000L (per dwelling)
Floor Area (building):	110 m2 (per dwelling)	Household water appliances: (per dwelling)	12x shower, basin, 6 x wc, kitch sink, laund tub, wm.

**Category 1:**  
**Courtyard, Terrace, Townhouse**  
 Water Sensitive Design  
 Infill Opportunities, Monash University  
 2012

- permeable surface - people
- permeable surface - car
- non-permeable surface
- non-permeable surface - usable
- deck / terrace
- garden
- garden - usable
- tree
- deep root zone
- capture
- store
- infiltrate (full)
- infiltrate (partial)

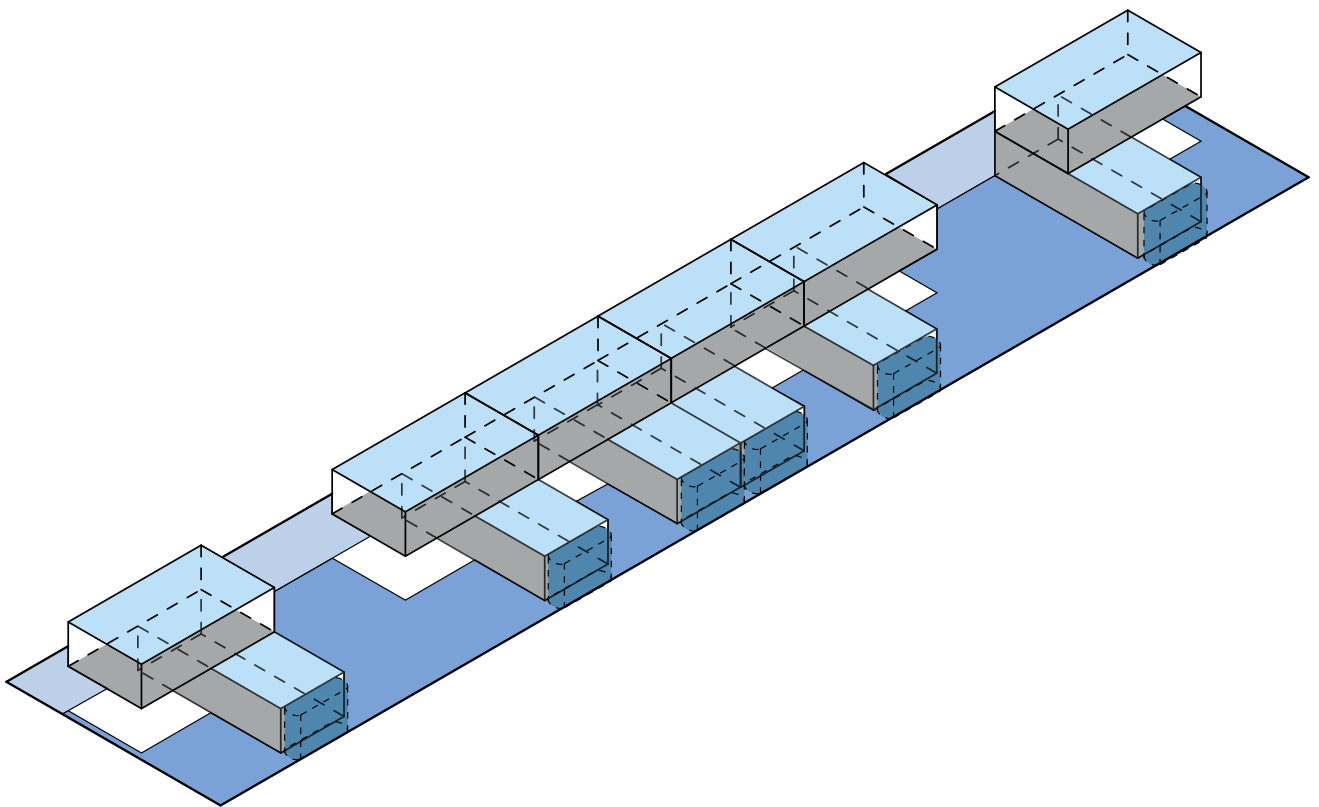

**axo (water)**



**Category 1:**  
**Courtyard, Terrace, Townhouse**  
 Water Sensitive Design  
 Infill Opportunities, Monash University  
 2012

- permeable surface - people
- permeable surface - car
- non-permeable surface
- non-permeable surface - usable
- deck / terrace
- garden
- garden - usable
- tree
- deep root zone
- capture
- store
- infiltrate (full)
- infiltrate (partial)

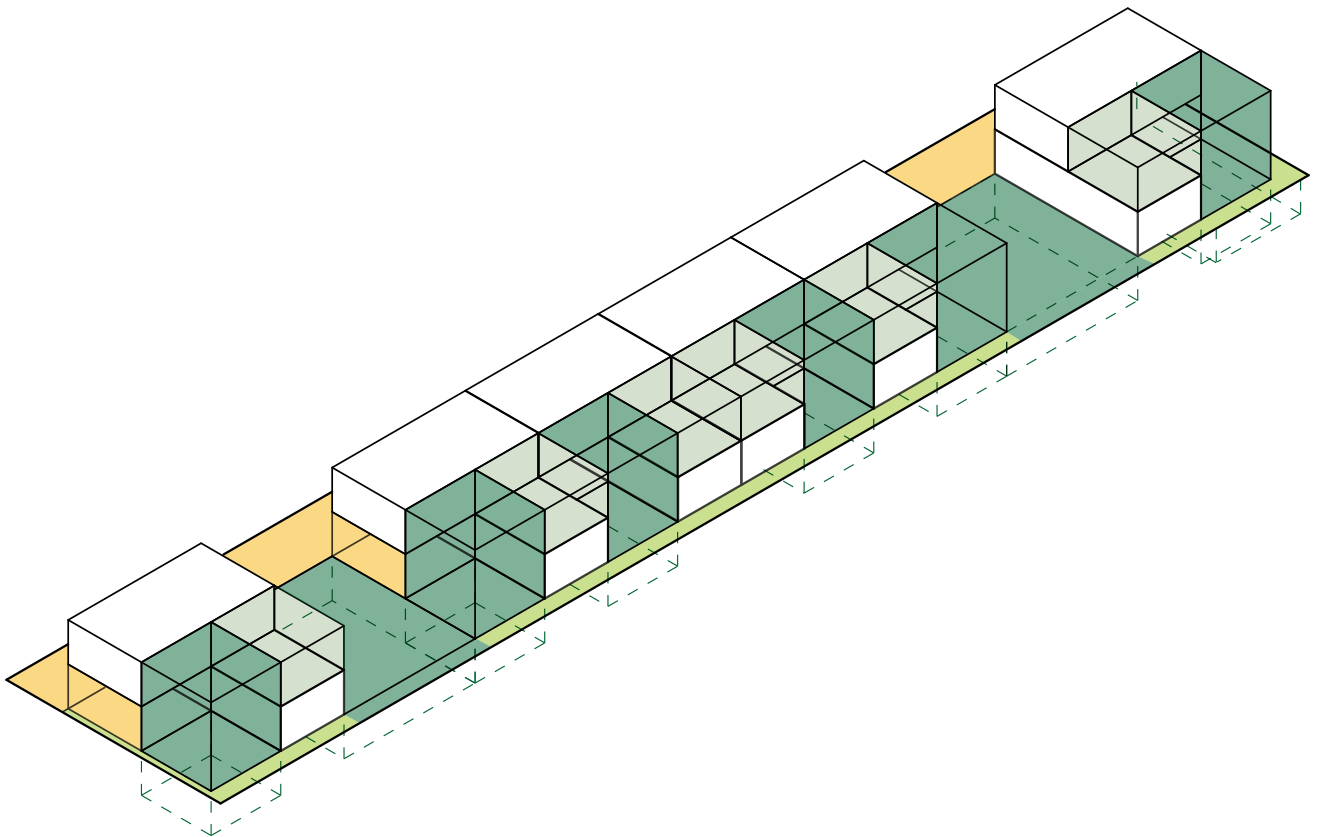

**axo (landscape)**

**Category 1:**  
**Courtyard, Terrace, Townhouse**  
 Existing Suburban Condition  
 Terrace House

- permeable surface - people
- permeable surface - car
- non-permeable surface
- non-permeable surface - usable
- deck / terrace
- garden
- garden - usable
- tree
- deep root zone
- capture
- store
- infiltrate (full)
- infiltrate (partial)

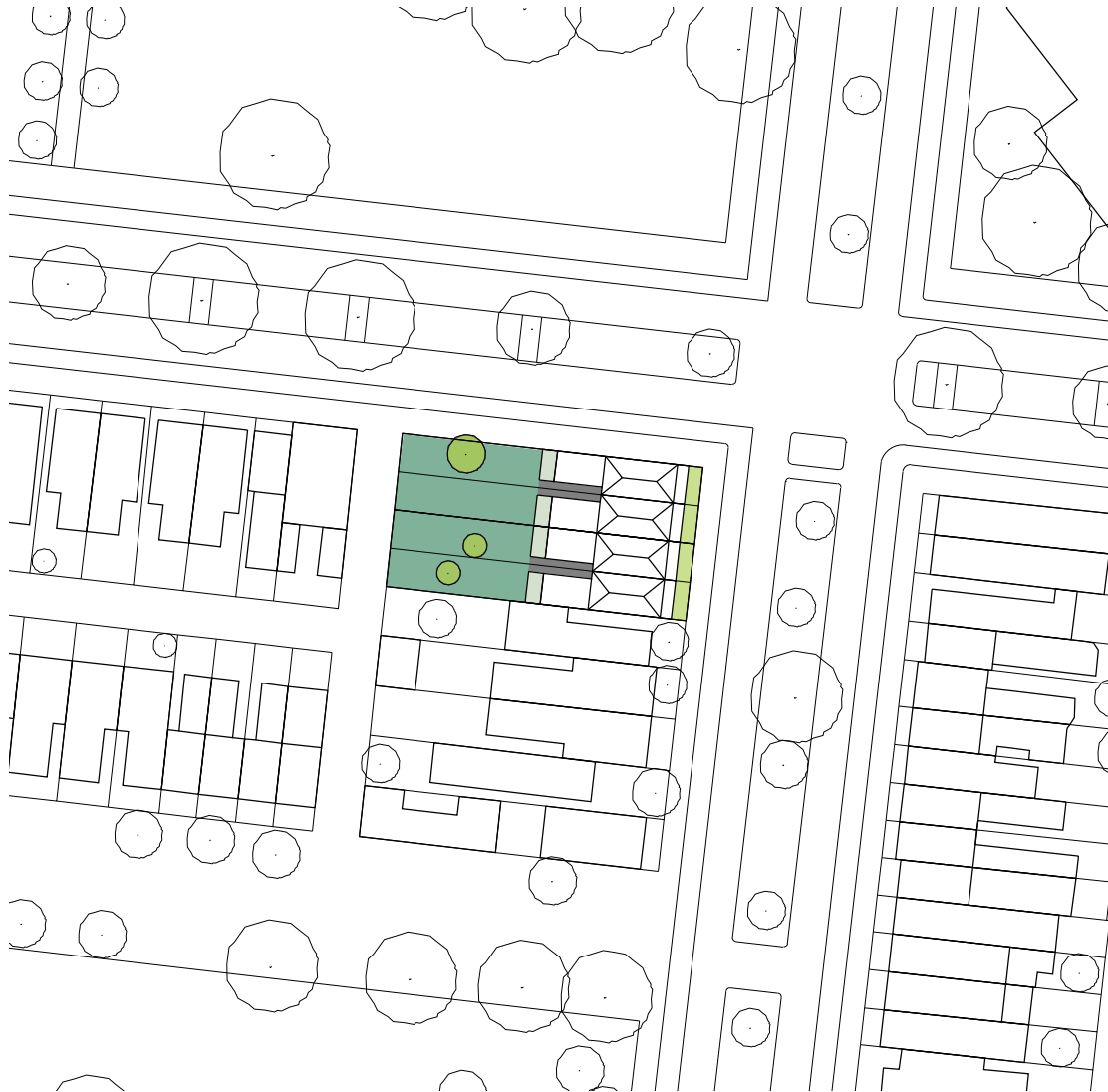

context plan 1/1000



<b>Site Data:</b>			
Site Area:	818 m2	Permeable Hard Surface:	34 m2
Number of Lots:	4	Non Permeable Hard Surface:	0 m2
Number of Dwellings:	4	Vegetated Surface:	418 m2
Density:	48 dwellings per hectare	Deep Root Zones:	8 (380 m2)
Open Space:	452 m2	Canopy Trees	3
Site Coverage:	45%	Additional On-Site Water Storage:	none

**Category 1:**  
**Courtyard, Terrace, Townhouse**  
 Existing Suburban Condition  
 Terrace House

- permeable surface - people
- permeable surface - car
- non-permeable surface
- non-permeable surface - usable
- deck / terrace
- garden
- garden - usable
- tree
- deep root zone
- capture
- store
- infiltrate (full)
- infiltrate (partial)

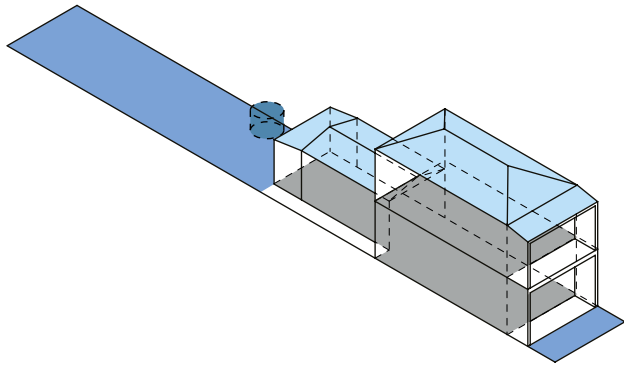

**axo (water)**

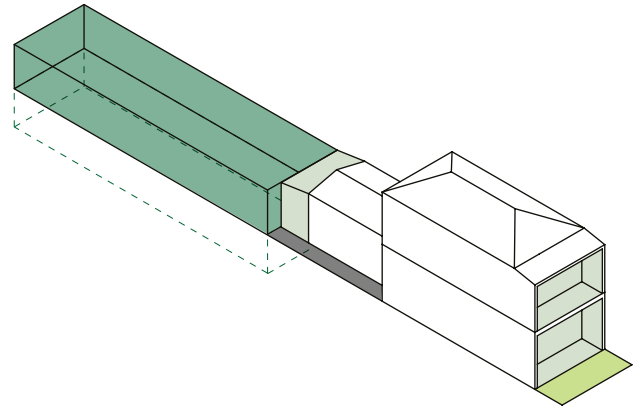

**axo (landscape)**

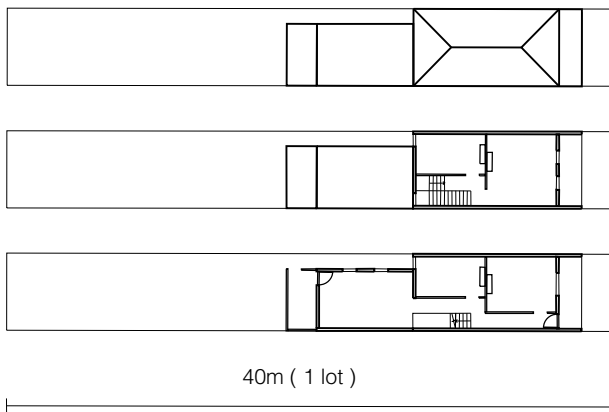

**plan 1 / 500**

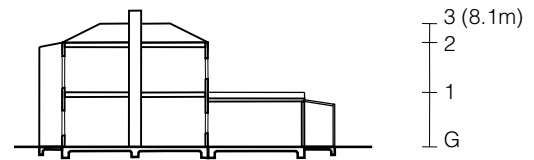

**section 1 / 500**

<b>Dwelling Data:</b>			
Bedrooms:	3 (per dwelling)	Floor Area (deck):	14
Occupants:	3-5 (per dwelling)	Garden Area:	94 m <sup>2</sup>
Cars:	1	Roof Surface Area:	91 m <sup>2</sup>
Building Storeys:	2	% of roof area connected to rainwater storage:	0%
Building Footprint:	91 m <sup>2</sup>	Rainwater Storage Capacity:	0 litres
Floor Area (building):	134 m <sup>2</sup>	Household water appliances: (per dwelling)	1 x basin, wc, shower, 1x kitch sink

**Category 1:**  
**Courtyard, Terrace, Townhouse**  
 Standard Industry Practice  
 Townhouse

- permeable surface - people
- permeable surface - car
- non-permeable surface
- non-permeable surface - usable
- deck / terrace
- garden
- garden - usable
- tree
- deep root zone
- capture
- store
- infiltrate (full)
- infiltrate (partial)

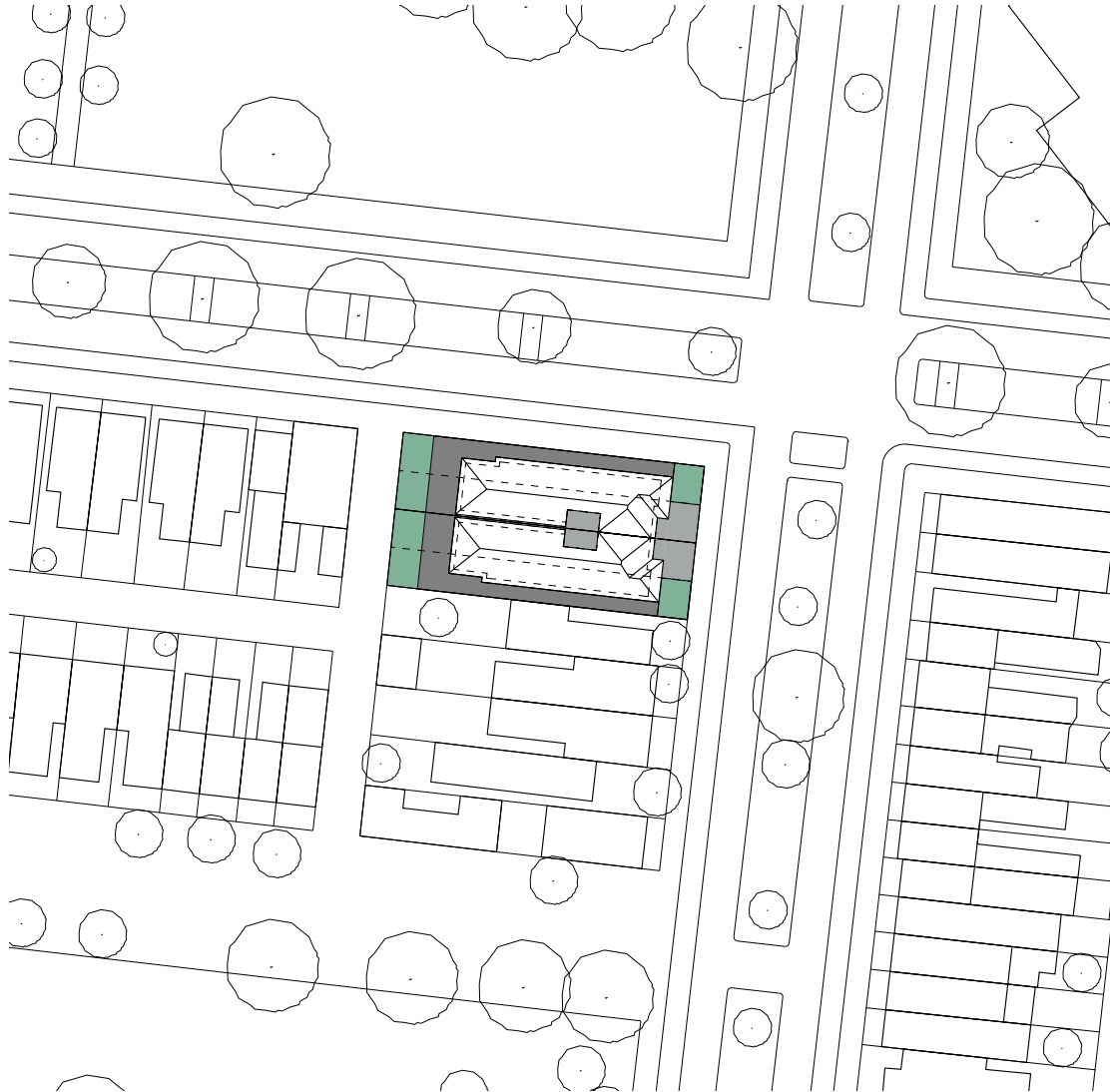

context plan 1/1000



Site Data			
Site Area:	818 m2	Permeable Hard Surface:	0 m2
Number of Lots:	2	Non Permeable Hard Surface:	312 m2
Number of Dwellings:	2	Vegetated Surface:	158 m2
Density:	24 dwellings per hectare	Deep Root Zones:	4 (158 m2)
Open Space:	470 m2	Canopy Trees	4
Site Coverage:	42%	Additional On-Site Water Storage:	rain water tank

**Category 1:**  
**Courtyard, Terrace, Townhouse**  
 Standard Industry Practice  
 Townhouse

- permeable surface - people
- permeable surface - car
- non-permeable surface
- non-permeable surface - usable
- deck / terrace
- garden
- garden - usable
- tree
- deep root zone
- capture
- store
- infiltrate (full)
- infiltrate (partial)

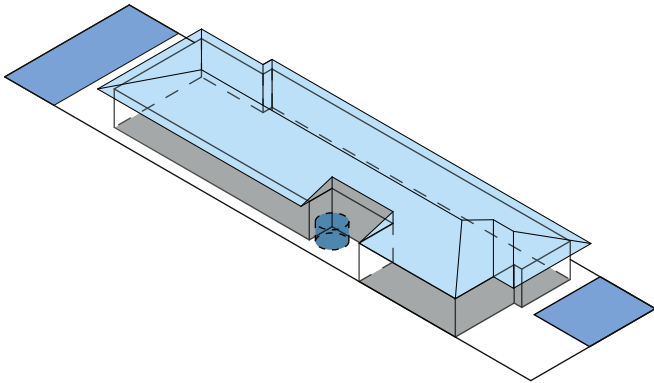

**axo (water)**

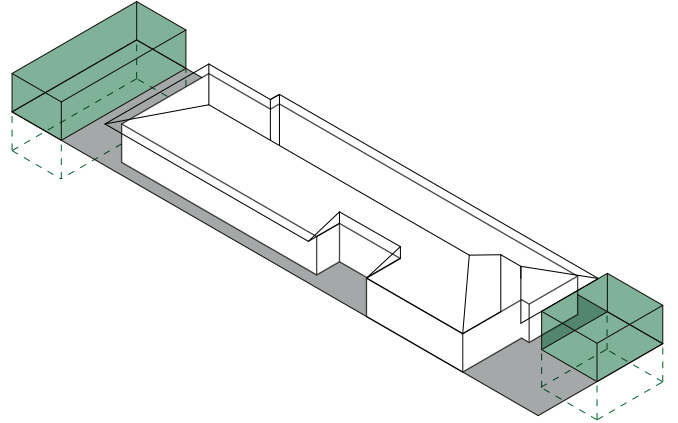

**axo (landscape)**

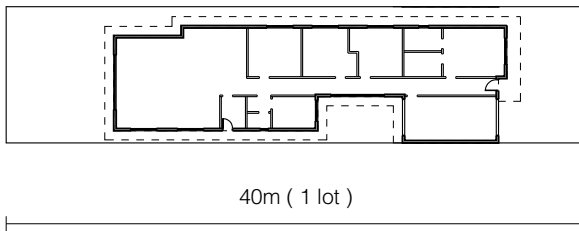

**plan 1 / 500**

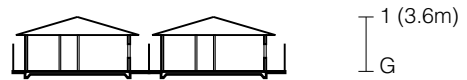

**section 1 / 500**

<b>Dwelling Data:</b>			
Bedrooms:	4 (per dwelling)	Floor Area (deck):	0 m2 (per dwelling)
Occupants:	4 to 6 (per dwelling)	Garden Area:	91 m2 (per dwelling)
Cars:	2 (per dwelling)	Roof Surface Area:	209 m2 (per dwelling)
Building Storeys:	1	% of roof area connected to rainwater storage:	40%
Building Footprint:	174 m2 (per dwelling)	Rainwater Storage Capacity:	2000 litres (per dwelling)
Floor Area (building):	174 m2 (per dwelling)	Household water appliances: (per dwelling)	2xshwr, basin, wc, 1xbath, kitch sink, laun tub, wm

**Category 1:**  
**Courtyard, Terrace, Townhouse**  
 Water Sensitive Design  
 Terrace House

- permeable surface - people
- permeable surface - car
- non-permeable surface
- non-permeable surface - usable
- deck / terrace
- garden
- garden - usable
- tree
- deep root zone
- capture
- store
- infiltrate (full)
- infiltrate (partial)

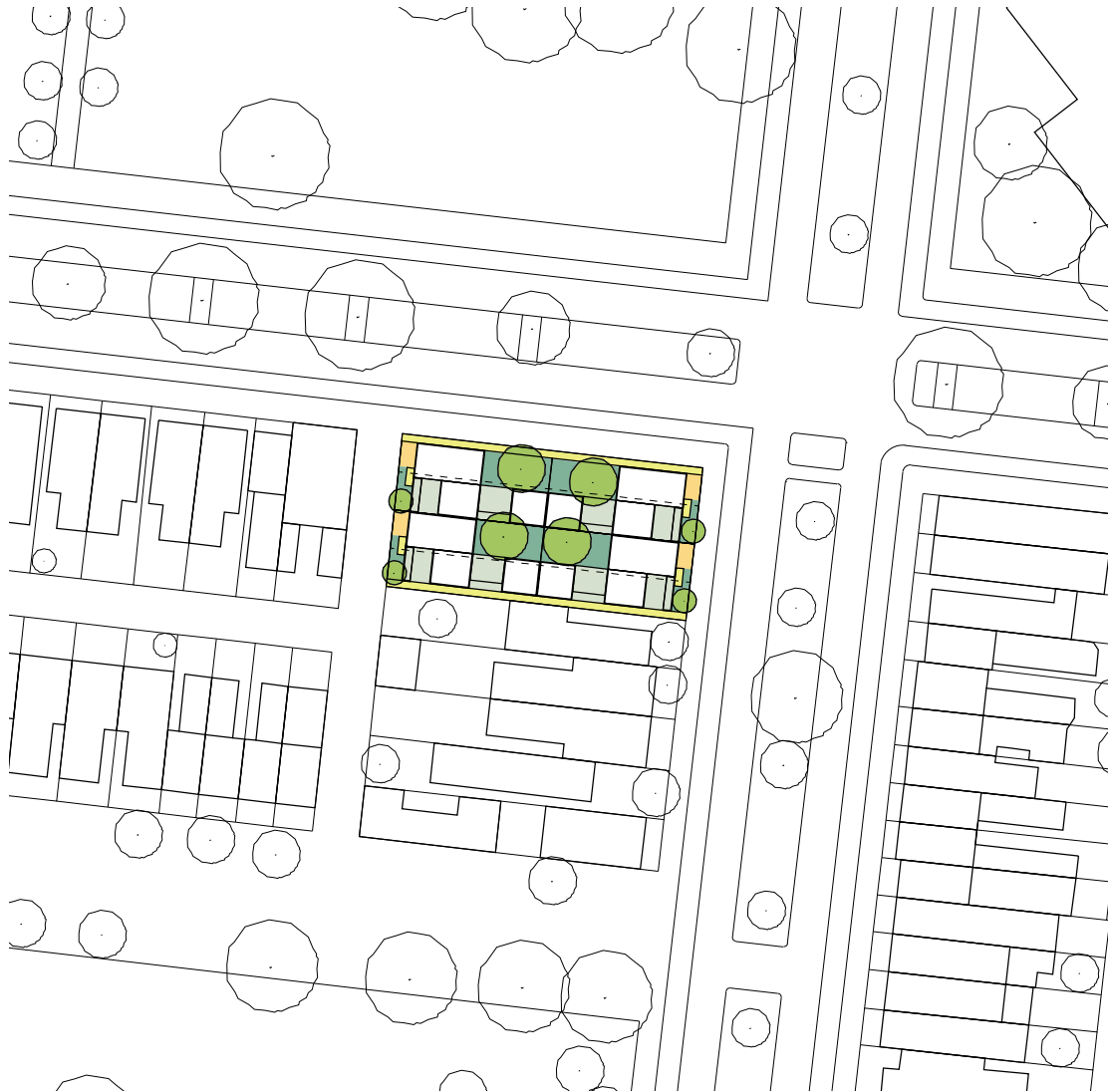

context plan 1/1000



Site Data			
Site Area:	818 m2	Permeable Hard Surface:	113 m2
Number of Lots:	4	Non Permeable Hard Surface:	0 m2
Number of Dwellings:	4	Vegetated Surface:	209 m2
Density:	48 dwellings per hectare	Deep Root Zones:	4 (165 m2)
Open Space:	322 m2	Canopy Trees	4
Site Coverage:	40%	Additional On-Site Water Storage:	rain water tank

**Category 1:**  
**Courtyard, Terrace, Townhouse**  
 Water Sensitive Design  
 Terrace House

- permeable surface - people
- permeable surface - car
- non-permeable surface
- non-permeable surface - usable
- deck / terrace
- garden
- garden - usable
- tree
- deep root zone
- capture
- store
- infiltrate (full)
- infiltrate (partial)

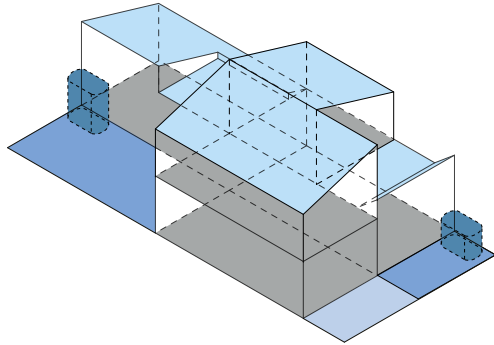

**axo (water)**

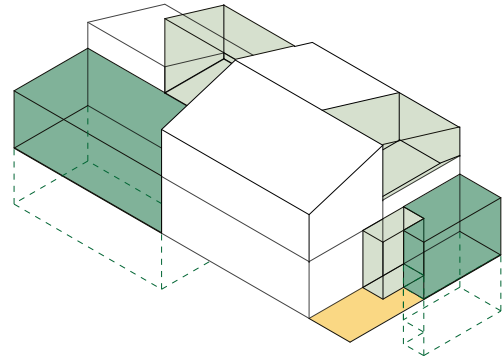

**axo (landscape)**

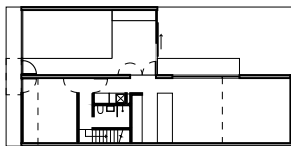

**first floor plan 1 / 500**

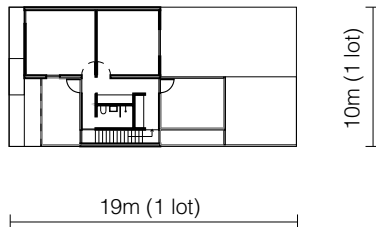

**ground plan 1 / 500**



**section 1 / 500**

<b>Dwelling Data:</b>			
Bedrooms:	3 (per dwelling)	Floor Area (deck):	34 m2 (per dwelling)
Occupants:	4 to 5 (per dwelling)	Garden Area:	52 m2 (per dwelling)
Cars:	1 (per dwelling)	Roof Surface Area:	94 m2 (per dwelling)
Building Storeys:	1	% of roof area connected to rainwater storage:	100%
Building Footprint:	124 m2 (per dwelling)	Rainwater Storage Capacity:	2500L (per dwelling)
Floor Area (building):	180 m2 (per dwelling)	Household water appliances: (per dwelling)	2 x basin, wc, shower, kitch sink. 1 x laund tub, wm.

**Category 1:**  
**Courtyard, Terrace, Townhouse**  
 Water Sensitive Design  
 Salisbury Terrace  
 Monash University &  
 University of Western Australia 2019

- permeable surface - people
  - permeable surface - car
  - non-permeable surface
  - non-permeable surface - usable
- deck / terrace
  - garden
  - garden - usable
  - tree
  - deep root zone
- capture
  - store
  - infiltrate (full)
  - infiltrate (partial)

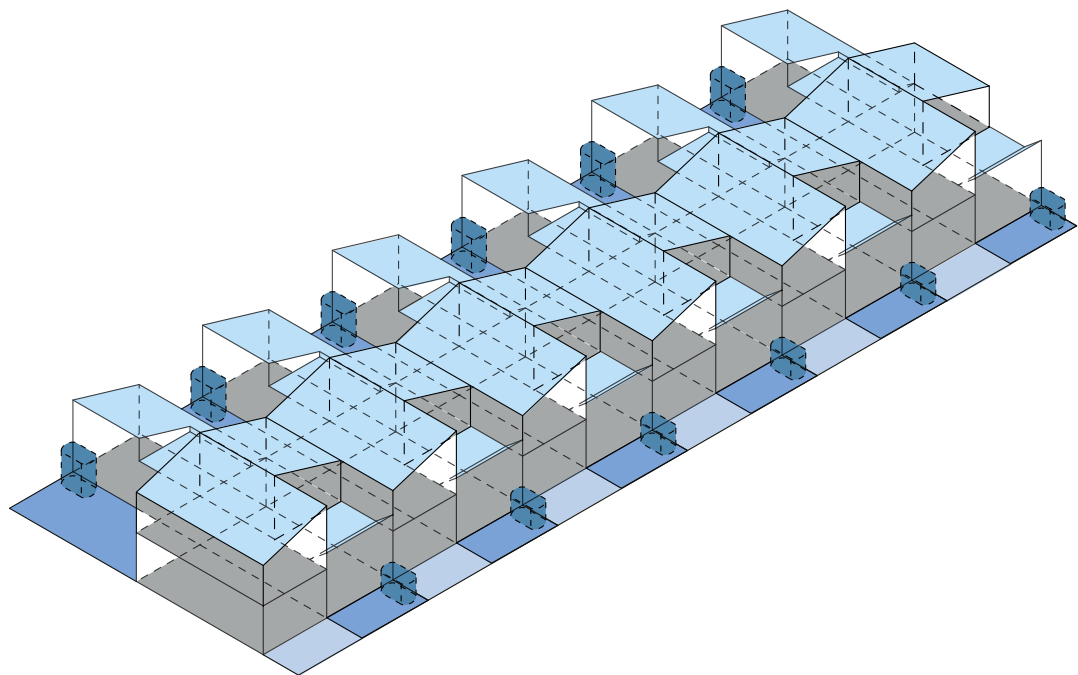

**axo (landscape)**



**Category 1:**  
**Courtyard, Terrace, Townhouse**  
 Water Sensitive Design  
 Salisbury Terrace  
 Monash University &  
 University of Western Australia 2019

- permeable surface - people
- permeable surface - car
- non-permeable surface
- non-permeable surface - usable
- deck / terrace
- garden
- garden - usable
- tree
- deep root zone
- capture
- store
- infiltrate (full)
- infiltrate (partial)

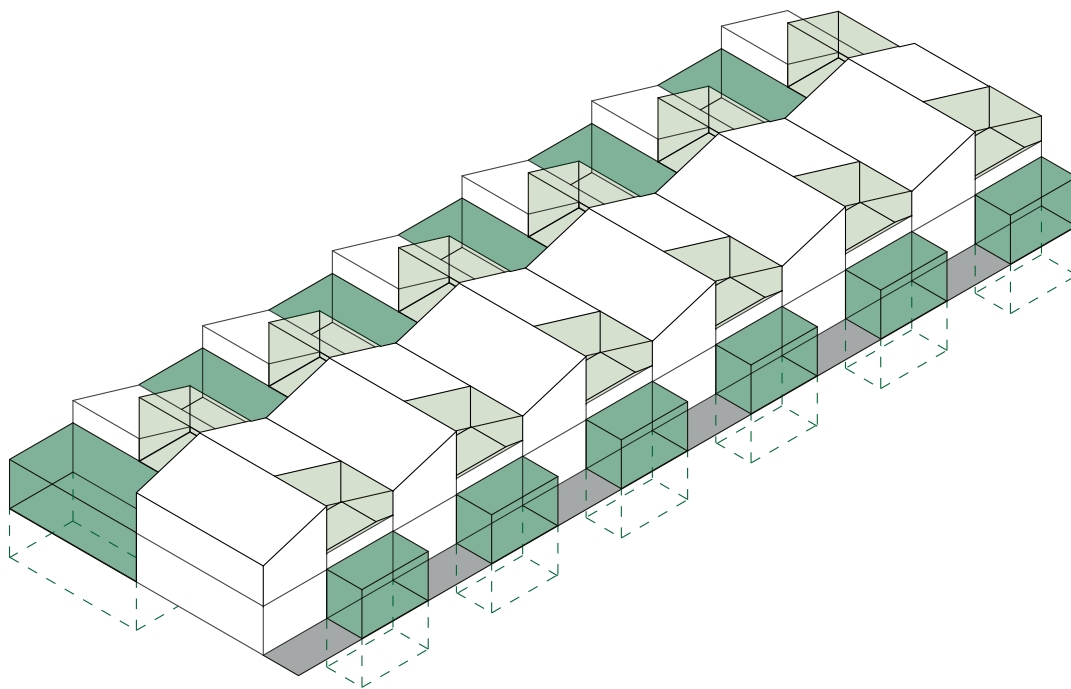

**axo (water)**

# Category 1: Courtyard, Terrace, Townhouse

Redcliffe Courtyard

Monash University &

University of Western Australia 2017

- permeable surface - people
- permeable surface - car
- non-permeable surface
- non-permeable surface - usable
- deck / terrace
- garden
- garden - usable
- tree
- deep root zone
- capture
- store
- infiltrate (full)
- infiltrate (partial)

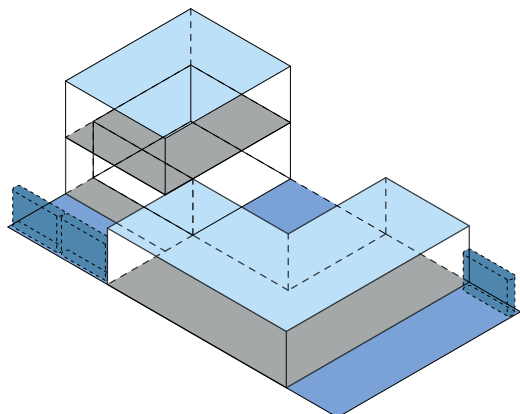

axo (water)

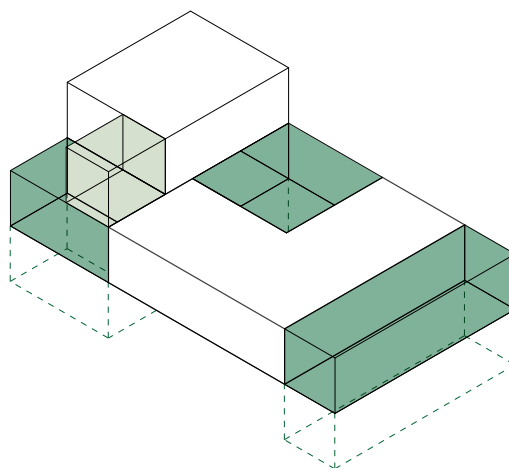

axo (landscape)

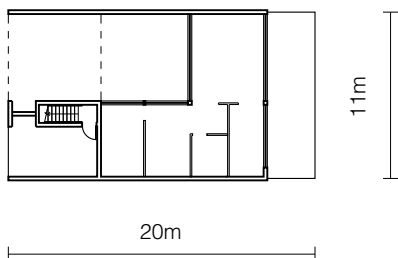

plan 1 / 500

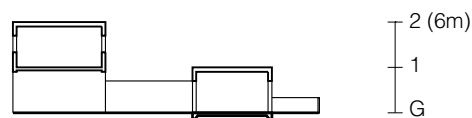

section 1 / 500

Dwelling Data:			
Bedrooms:	2 beds and 1 bed (per dwelling)	Floor Area (deck):	8 m <sup>2</sup>
Occupants:	2 to 5 (per dwelling)	Garden Area:	130 m <sup>2</sup>
Cars:	2 (per dwelling)	Roof Surface Area:	136 m <sup>2</sup>
Building Storeys:	2	% of roof area connected to rainwater storage:	100%
Building Footprint:	100 m <sup>2</sup>	Rainwater Storage Capacity:	5000L
Floor Area (building):	120 m <sup>2</sup>	Household water appliances: (per dwelling)	2 x basin, wc, shower, kitch sink. 1 x laun tub, wm.

**Category 1:**  
**Courtyard, Terrace, Townhouse**  
 Salisbury Courtyard  
 Monash University &  
 University of Western Australia 2018

- permeable surface - people
- permeable surface - car
- non-permeable surface
- non-permeable surface - usable
- deck / terrace
- garden
- garden - usable
- tree
- deep root zone
- capture
- store
- infiltrate (full)
- infiltrate (partial)

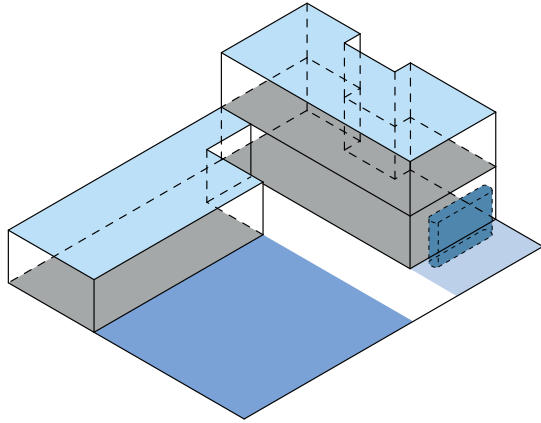

**axo (water)**

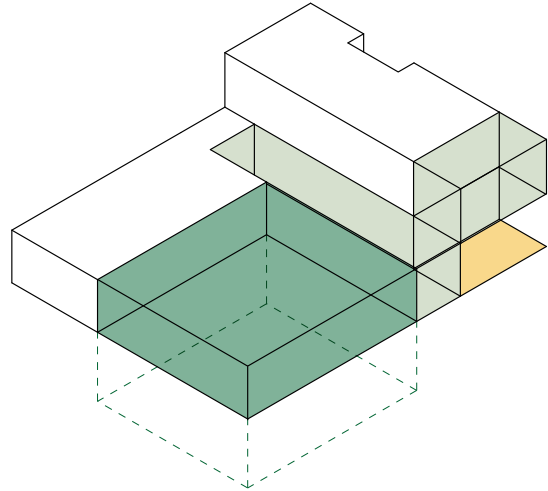

**axo (landscape)**

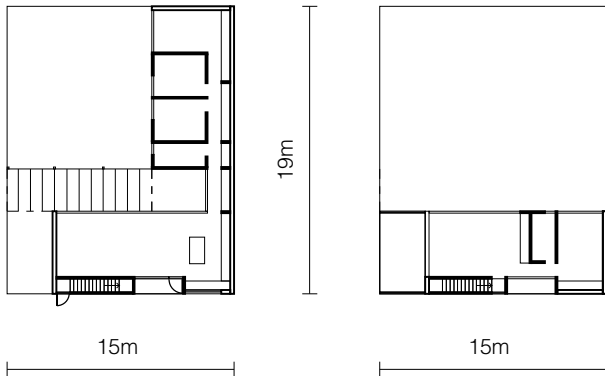

**plan 1 / 500**

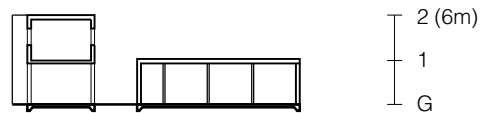

**section 1 / 500**

<b>Dwelling Data:</b>			
Bedrooms:		Floor Area (deck):	
Occupants:		Garden Area:	
Cars:		Roof Surface Area:	
Building Storeys:		% of roof area connected to rainwater storage:	
Building Footprint:		Rainwater Storage Capacity:	
Floor Area (building):		Household water appliances: (per dwelling)	

**Category 1:**  
**Courtyard, Terrace, Townhouse**  
 Bowden Terraces  
 Tridente Architects 2014

- permeable surface - people
- permeable surface - car
- non-permeable surface
- non-permeable surface - usable
- deck / terrace
- garden
- garden - usable
- tree
- deep root zone
- capture
- store
- infiltrate (full)
- infiltrate (partial)

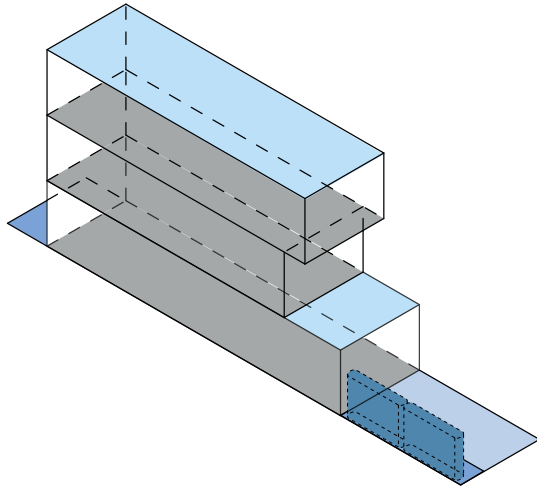

**axo (water)**

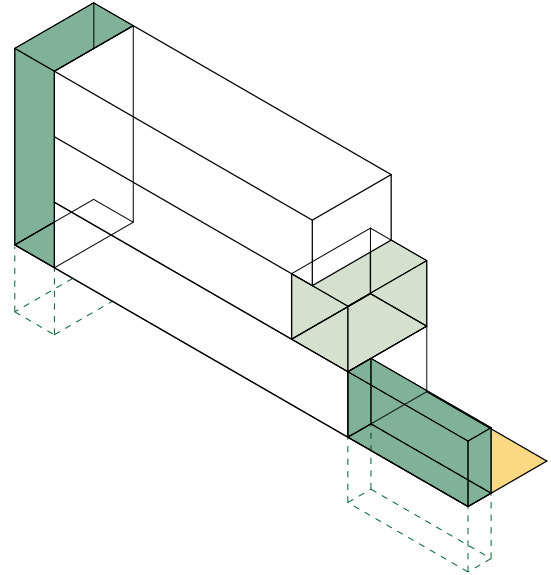

**axo (landscape)**

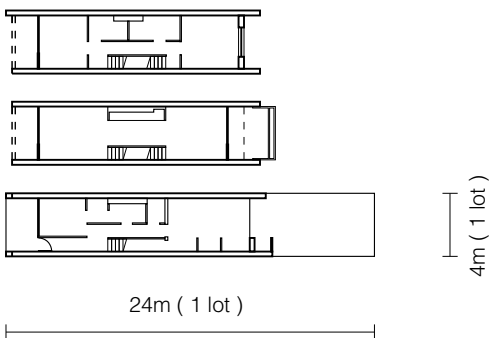

**plan 1 / 500**

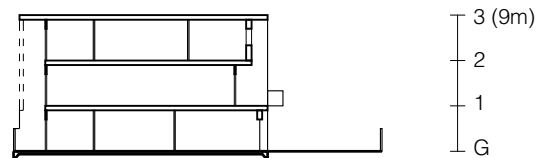

**section 1 / 500**

<b>Dwelling Data:</b>			
Bedrooms:	3 (per dwelling)	Floor Area (deck):	0 m2 (per dwelling)
Occupants:	2 to 5 (per dwelling)	Garden Area:	22 m2 (per dwelling)
Cars:	2 (per dwelling)	Roof Surface Area:	72 m2 (per dwelling)
Building Storeys:	3	% of roof area connected to rainwater storage:	100%
Building Footprint:	60 m2 (per dwelling)	Rainwater Storage Capacity:	2000L (per dwelling)
Floor Area (building):	142 m2 (per dwelling)	Household water appliances: (per dwelling)	3 x basin, wc, shower, 1 x laun tub, wm, kitch sink

## Category 2: Stacked, Cluster

The stacked dwelling typology is a vertical strata-titled construction with units stacked on top of each other and accessed from shared vertical stair halls rather than a horizontal corridor. By stacking, each unit achieves more desirable solar access and cross-ventilation for both indoor and outdoor private spaces. A variety of outdoor private spaces is compatible with this typology: patios, courtyards, front yards, balconies and terraces. Each dwelling can be designed with its own direct access from the street, and they are often positioned on lots sandwiched in between two streets. Stacked constructions are typically three to five storeys high, developed on a single lot or two adjoining lots, achieving density from 40 to 60 dwellings per hectare. When attached to form clusters, on three and more consolidated lots, even higher density is achieved.

Cluster typology refers to a group of strata-titled dwellings, courtyard houses, terraced houses or townhouses, most commonly sharing one or more boundary walls. Clustered developments sit on two or more consolidated lots, and are typically two to three storeys high, with possibilities for more efficient and effective use of outdoor space.

## Category 2: Stacked, Cluster

Existing Condition

Infill Opportunities, Monash University  
2012

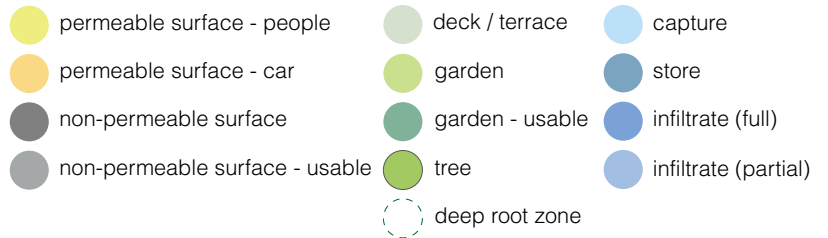

context plan 1/1000



Site Data			
Site Area:	1262 m2	Permeable Hard Surface:	257 m2
Number of Lots:	2	Non Permeable Hard Surface:	0 m2
Number of Dwellings:	2	Vegetated Surface:	672 m2
Density:	16 dwellings per hectare	Deep Root Zones:	4 (672 m2)
Open Space:	929 m2	Canopy Trees	12+
Site Coverage:	26%	Additional On-Site Water Storage:	rain water tank

## Category 2: Stacked, Cluster

Existing Condition

Infill Opportunities, Monash University  
2012

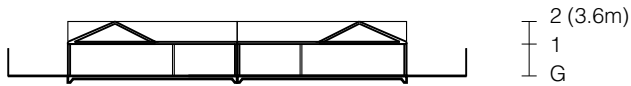
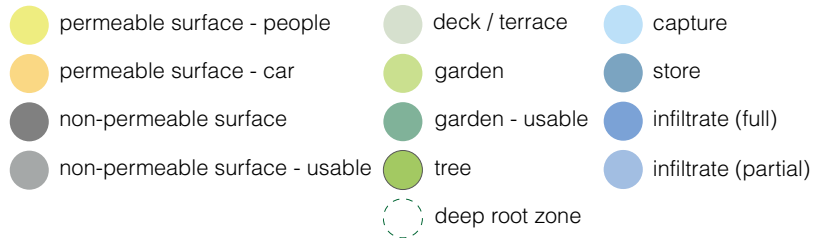

section 1 / 500

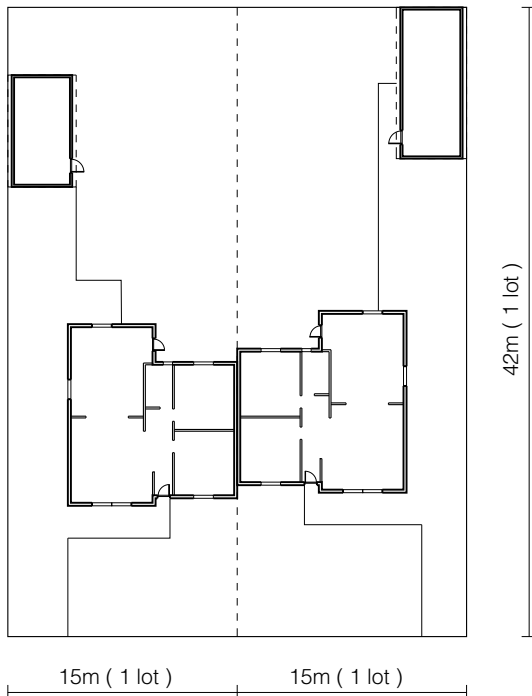

plan 1 / 500

<b>Dwelling Data:</b>			
Bedrooms:	?	Floor Area (deck):	?
Occupants:	?	Garden Area:	? m2
Cars:	?	Roof Surface Area:	? m2
Building Storeys:	?	% of roof area connected to rainwater storage:	?%
Building Footprint:	? m2	Rainwater Storage Capacity:	? litres
Floor Area (building):	? m2	Household water appliances: (per dwelling)	? x basin, wc, shower, ? x laun tub, wm, kitch sink

**Category 2: Stacked, Cluster**  
 Standard Industry Practice  
 Infill Opportunities, Monash University  
 2012

- permeable surface - people
- permeable surface - car
- non-permeable surface
- non-permeable surface - usable
- deck / terrace
- garden
- garden - usable
- tree
- deep root zone
- capture
- store
- infiltrate (full)
- infiltrate (partial)



context plan 1/1000



Site Data			
Site Area:	1262 m2	Permeable Hard Surface:	0 m2
Number of Lots:	2	Non Permeable Hard Surface:	357 m2
Number of Dwellings:	4	Vegetated Surface:	398 m2
Density:	32 dwellings per hectare	Deep Root Zones:	3 (151 m2)
Open Space:	755 m2	Canopy Trees	3
Site Coverage:	40%	Additional On-Site Water Storage:	rain water tank



**Category 2: Stacked, Cluster**  
 Standard Industry Practice  
 Infill Opportunities, Monash University  
 2012

- permeable surface - people
- permeable surface - car
- non-permeable surface
- non-permeable surface - usable
- deck / terrace
- garden
- garden - usable
- tree
- deep root zone
- capture
- store
- infiltrate (full)
- infiltrate (partial)

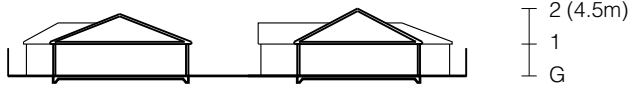

**section 1 / 500**

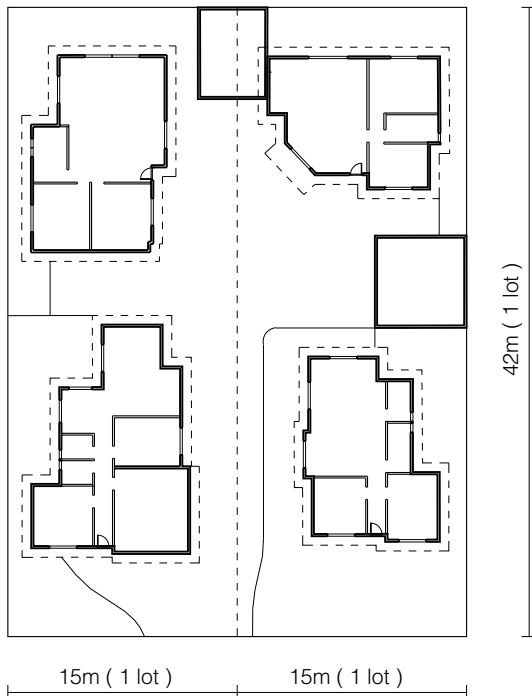

**plan 1 / 500**

<b>Dwelling Data:</b>			
Bedrooms:	?	Floor Area (deck):	?
Occupants:	?	Garden Area:	? m2
Cars:	?	Roof Surface Area:	? m2
Building Storeys:	?	% of roof area connected to rainwater storage:	?%
Building Footprint:	? m2	Rainwater Storage Capacity:	? litres
Floor Area (building):	? m2	Household water appliances: (per dwelling)	? x basin, wc, shower, ? x laun tub, wm, kitch sink

## Category 2: Stacked, Cluster

Water Sensitive Design

Infill Opportunities, Monash University

2012

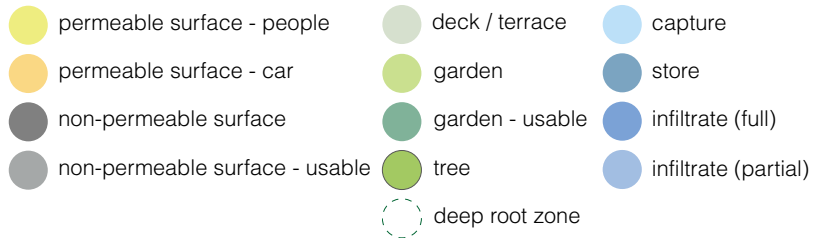

context plan 1/1000



Site Data			
Site Area:	1262 m2	Permeable Hard Surface:	434 m2
Number of Lots:	2	Non Permeable Hard Surface:	0 m2
Number of Dwellings:	6	Vegetated Surface:	483 m2
Density:	47 dwellings per hectare	Deep Root Zones:	4 (312 m2)
Open Space:	917 m2	Canopy Trees	8+
Site Coverage:	28%	Additional On-Site Water Storage:	Communal water storage

**Category 2: Stacked, Cluster**  
 Water Sensitive Design  
 Infill Opportunities, Monash University  
 2012

- permeable surface - people
- permeable surface - car
- non-permeable surface
- non-permeable surface - usable
- deck / terrace
- garden
- garden - usable
- tree
- deep root zone
- capture
- store
- infiltrate (full)
- infiltrate (partial)

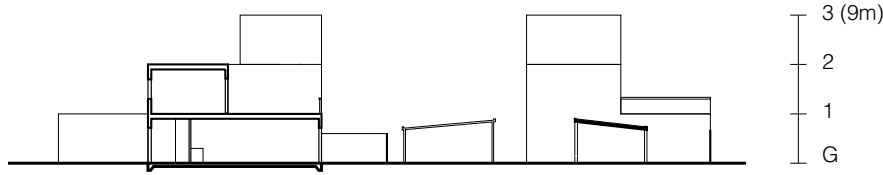

**section 1 / 500**

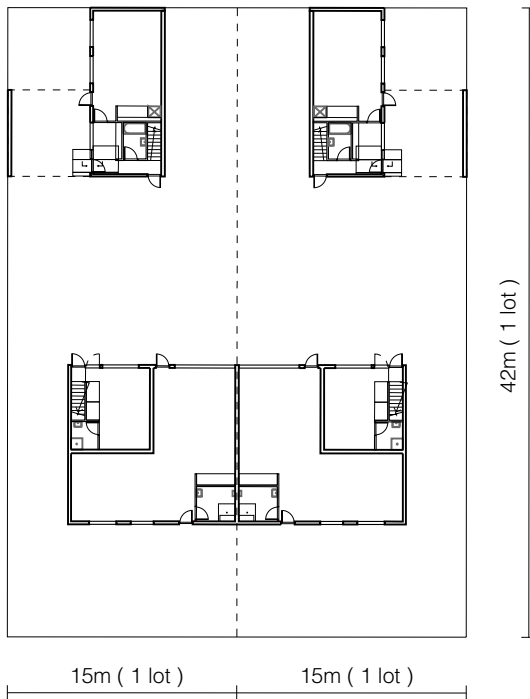

**ground plan 1 / 500**

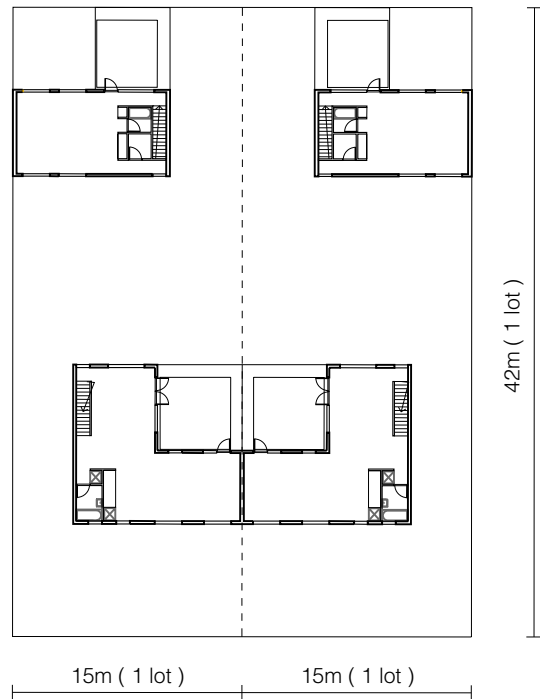

**first floor plan 1 / 500**

<b>Dwelling Data:</b>			
Bedrooms:	2 and 3 (per dwelling)	Floor Area (deck):	132 m2 (all dwellings)
Occupants:	2 to 5 (per dwelling)	Garden Area:	483 m2 (all dwellings)
Cars:	2 (per dwelling)	Roof Surface Area:	280 m2 (all dwellings)
Building Storeys:	2 (3)	% of roof area connected to rainwater storage:	100%
Building Footprint:	345 m2	Rainwater Storage Capacity:	20000 litres
Floor Area (building):	604 m2	Household water appliances: (per dwelling)	12 x basin, wc, shower, ? x laun tub, wm, kitch sink

**Category 2: Stacked, Cluster**  
 Water Sensitive Design  
 Infill Opportunities, Monash University  
 2012

- permeable surface - people
- permeable surface - car
- non-permeable surface
- non-permeable surface - usable
- deck / terrace
- garden
- garden - usable
- tree
- deep root zone
- capture
- store
- infiltrate (full)
- infiltrate (partial)

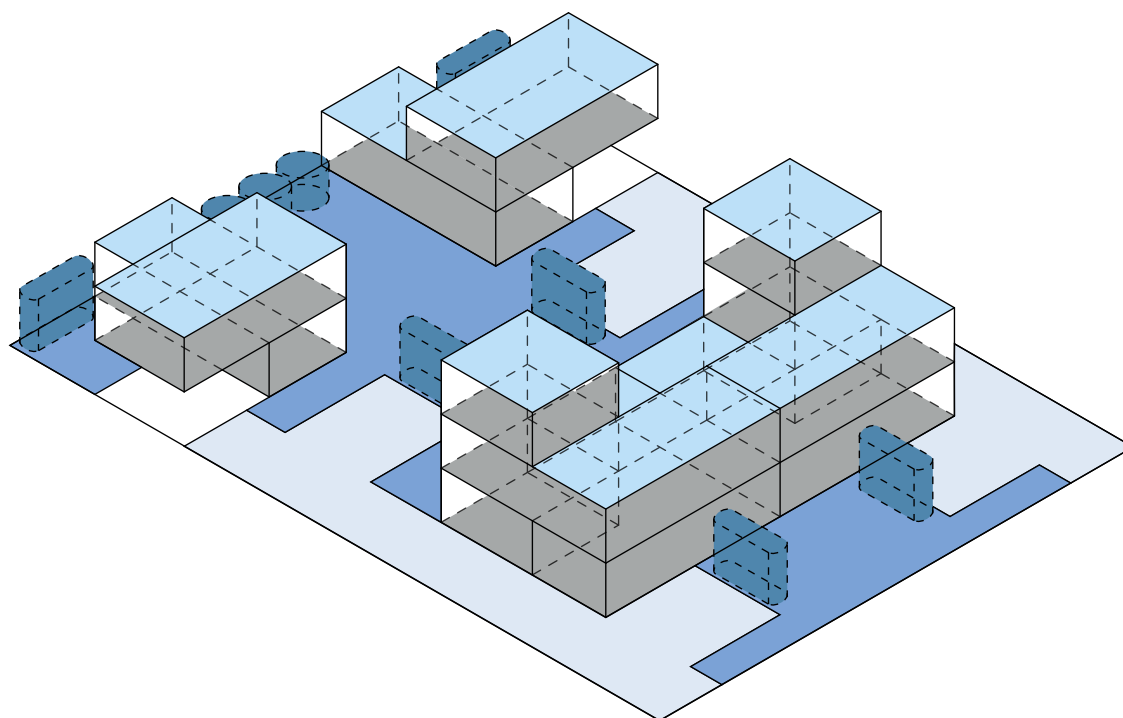

**axo (water)**

**Category 2: Stacked, Cluster**  
 Water Sensitive Design  
 Infill Opportunities, Monash University  
 2012

- permeable surface - people
- permeable surface - car
- non-permeable surface
- non-permeable surface - usable
- deck / terrace
- garden
- garden - usable
- tree
- deep root zone
- capture
- store
- infiltrate (full)
- infiltrate (partial)

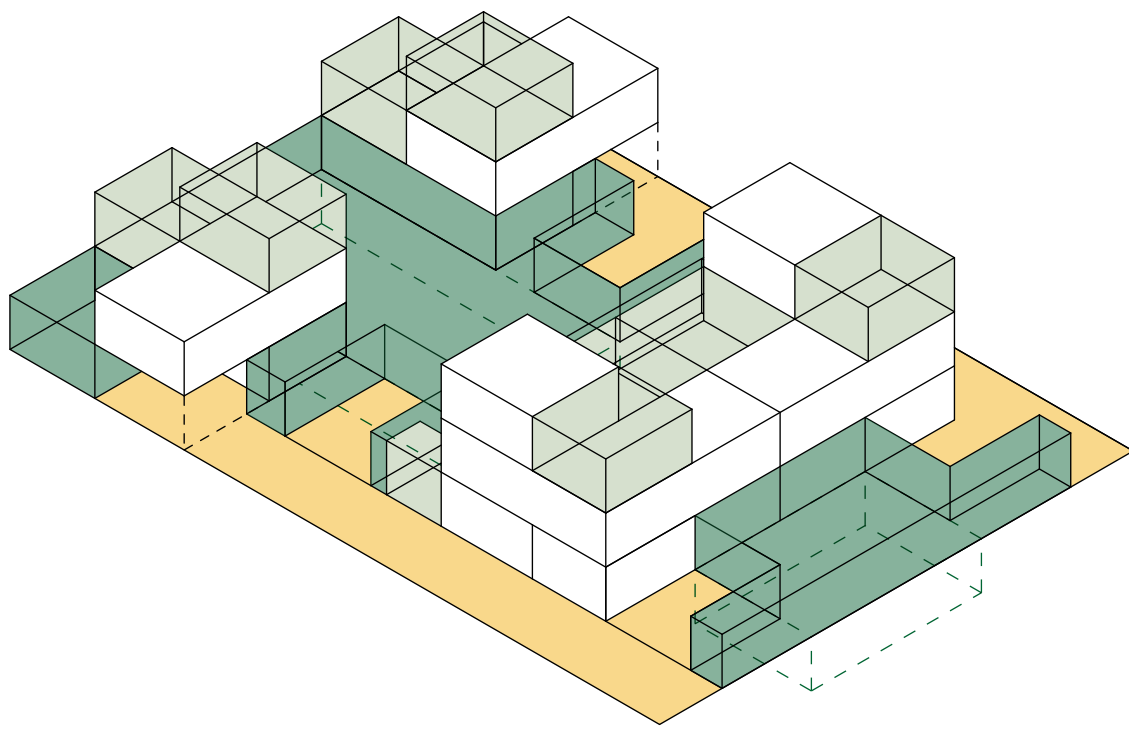

**axo (landscape)**

**Category 2: Stacked, Cluster**  
 Water Sensitive Design  
 Infill Opportunities, Monash University  
 2012

- permeable surface - people
- permeable surface - car
- non-permeable surface
- non-permeable surface - usable
- deck / terrace
- garden
- garden - usable
- tree
- deep root zone
- capture
- store
- infiltrate (full)
- infiltrate (partial)



context plan 1/1000



Site Data			
Site Area:	1751 m2	Permeable Hard Surface:	473 m2
Number of Lots:	3	Non Permeable Hard Surface:	0 m2
Number of Dwellings:	9	Vegetated Surface:	738 m2
Density:	51 dwellings per hectare	Deep Root Zones:	8 (650 m2)
Open Space:	1211 m2	Canopy Trees	14+
Site Coverage:	30%	Additional On-Site Water Storage:	Communal water storage

## Category 2: Stacked, Cluster

Water Sensitive Design

Infill Opportunities, Monash University

2012

- permeable surface - people
- permeable surface - car
- non-permeable surface
- non-permeable surface - usable
- deck / terrace
- garden
- garden - usable
- tree
- deep root zone
- capture
- store
- infiltrate (full)
- infiltrate (partial)

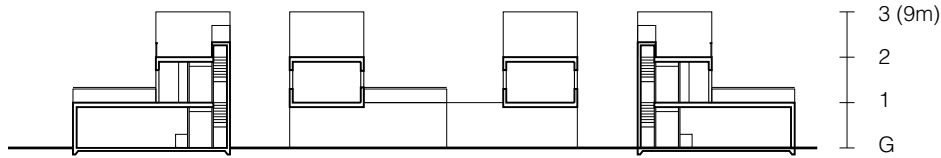

section 1 / 500

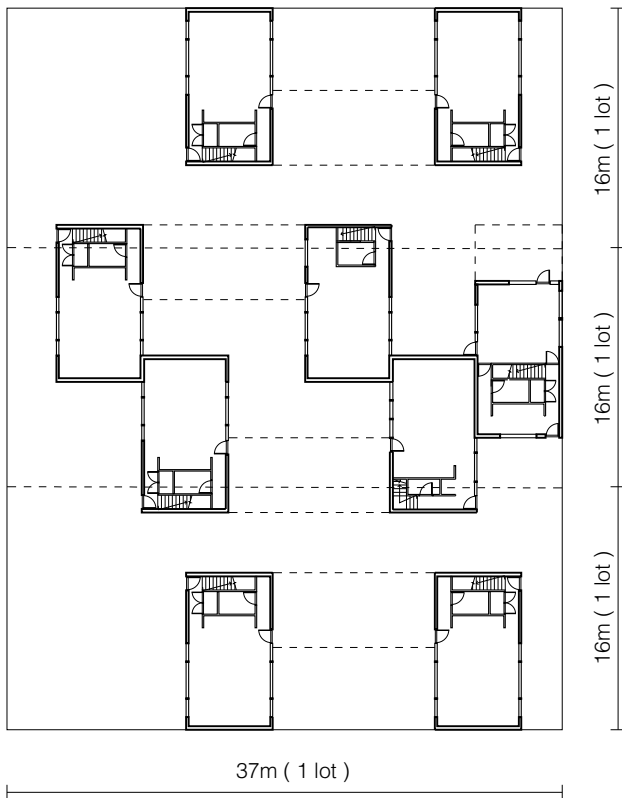

ground plan 1 / 500

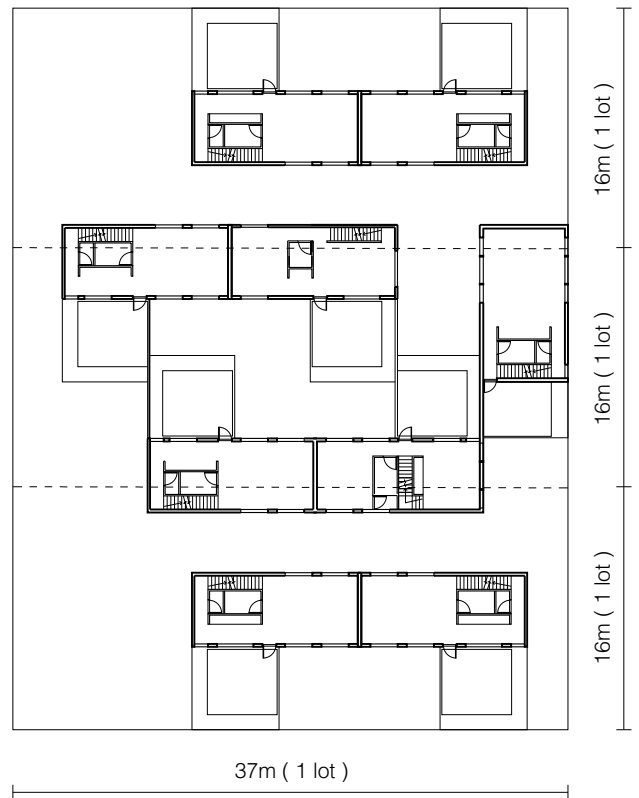

first floor plan 1 / 500



Dwelling Data:			
Bedrooms:	2 and 3 (per dwelling)	Floor Area (deck):	275 m2 (all dwellings)
Occupants:	2 to 5 (per dwelling)	Garden Area:	738 m2 (all dwellings)
Cars:	2 (per dwelling)	Roof Surface Area:	265 m2 (all dwellings)
Building Storeys:	2 (3)	% of roof area connected to rainwater storage:	100%
Building Footprint:	540 m2	Rainwater Storage Capacity:	25000L
Floor Area (building):	990 m2	Household water appliances: (per dwelling)	18 x basin, wc, shower, ? x laun tub, wm, kitch sink

**Category 2: Stacked, Cluster**  
Water Sensitive Design  
Infill Opportunities, Monash University  
2012

- permeable surface - people
- permeable surface - car
- non-permeable surface
- non-permeable surface - usable
- deck / terrace
- garden
- garden - usable
- tree
- deep root zone
- capture
- store
- infiltrate (full)
- infiltrate (partial)

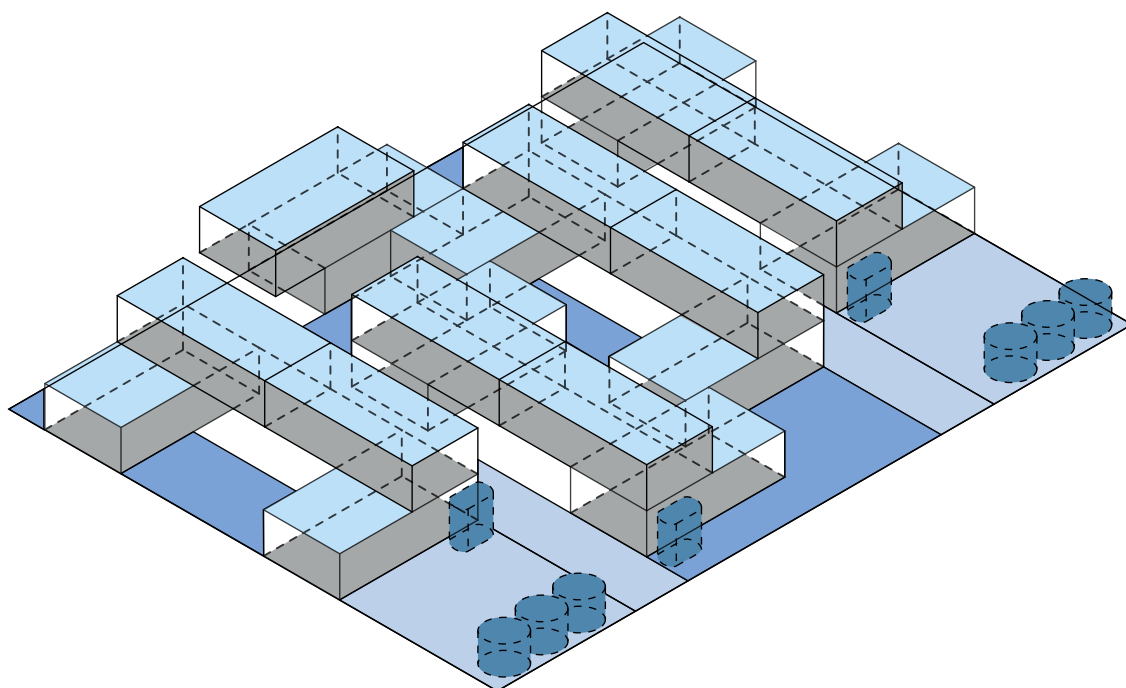

**axo (water)**



**Category 2: Stacked, Cluster**  
Water Sensitive Design  
Infill Opportunities, Monash University  
2012

- permeable surface - people
- permeable surface - car
- non-permeable surface
- non-permeable surface - usable
- deck / terrace
- garden
- garden - usable
- tree
- deep root zone
- capture
- store
- infiltrate (full)
- infiltrate (partial)

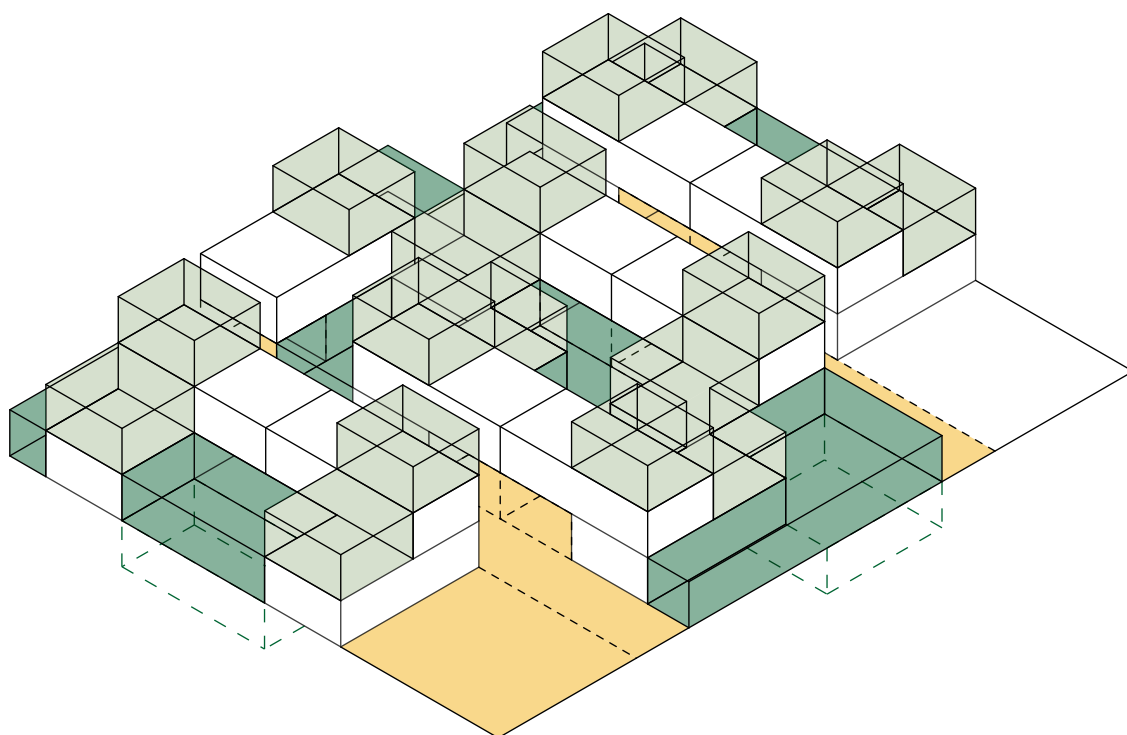

**axo (landscape)**

## Category 2: Stacked, Cluster

Water Sensitive Design

Gen Y House

David Barr Architects 2016

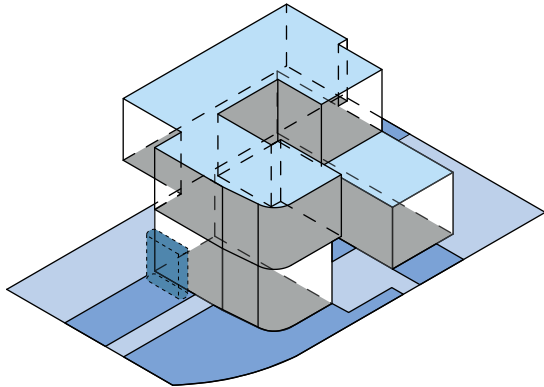
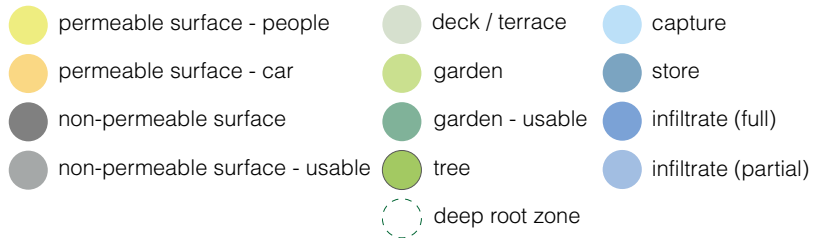

axo (water)

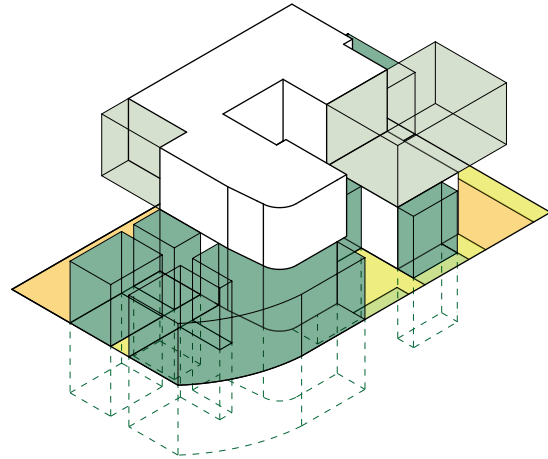

axo (landscape)

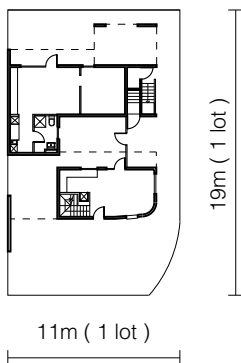

ground plan 1 / 500

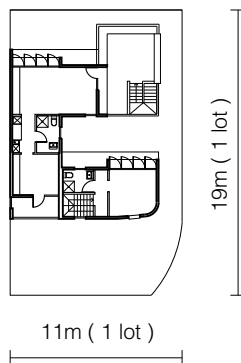

first floor plan 1 / 500

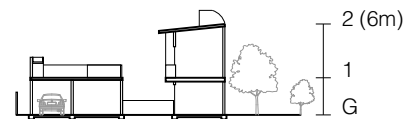

section 1 / 500

Dwelling Data:			
Bedrooms:	3 (1 per dwelling)	Floor Area (deck):	29
Occupants:	3-6 (1-2 per dwelling)	Garden Area:	59 m2
Cars:	3	Roof Surface Area:	74 m2
Building Storeys:	2	% of roof area connected to rainwater storage:	100%
Building Footprint:	65 m2	Rainwater Storage Capacity:	6000 litres
Floor Area (building):	123 m2	Household water appliances: (per dwelling)	3 x basin, wc, shower, 3 x laun tub, wm, kitch sink

## Category 3: 'Walk up' apartments

The 'six pack', and its variations, is a suburban low-rise apartment development, typically two to three storeys high. With typically six to 10 dwellings, this type achieves density of 40 to 60 dwellings per hectare. Depending on the site area, such developments can accommodate more dwellings while still complying with local building codes, such as height and setbacks. Each apartment has access to private outdoor space in the form of a balcony, terrace or patio, with shared spaces reserved for access, driveways, staircases and, more recently, lift core, grouped parking and other communal functions.

**Category 3:**  
**'Walk Up' Apartments**  
 Existing Suburban Condition  
 5 Apartments (1 Level)

- permeable surface - people
- permeable surface - car
- non-permeable surface
- non-permeable surface - usable
- deck / terrace
- garden
- garden - usable
- tree
- deep root zone
- capture
- store
- infiltrate (full)
- infiltrate (partial)



context plan 1/1000



Site Data			
Site Area:	1025 m2	Permeable Hard Surface:	0 m2
Number of Lots:	1	Non Permeable Hard Surface:	310 m2
Number of Dwellings:	5	Vegetated Surface:	305 m2
Density:	49 dwellings per hectare	Deep Root Zones:	1 (151 m2)
Open Space:	615 m2	Canopy Trees	1 to 2
Site Coverage:	40%	Additional On-Site Water Storage:	None

**Category 3:**  
**'Walk Up' Apartments**  
 Existing Suburban Condition  
 5 Apartments (1 Level)

- permeable surface - people
- permeable surface - car
- non-permeable surface
- non-permeable surface - usable
- deck / terrace
- garden
- garden - usable
- tree
- deep root zone
- capture
- store
- infiltrate (full)
- infiltrate (partial)

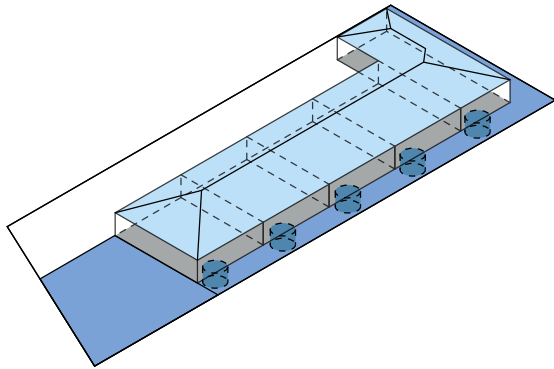

**axo (water)**

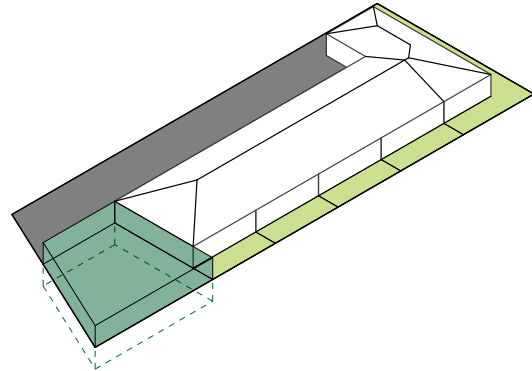

**axo (landscape)**

56.0 m ( 1 lot )

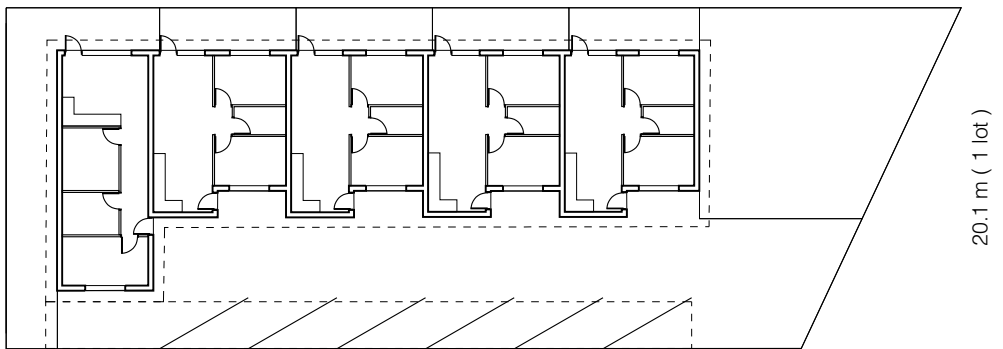

20.1 m ( 1 lot )

46.6 m ( 1 lot )

**plan 1 / 500**

<b>Dwelling Data:</b>			
Bedrooms:	1 and 2 (per dwelling)	Floor Area (deck):	0 m2 (all dwellings)
Occupants:	1 to 3 (per dwelling)	Garden Area:	305 m2 (all dwellings)
Cars:	5	Roof Surface Area:	410 m2 (all dwellings)
Building Storeys:	1	% of roof area connected to rainwater storage:	0%
Building Footprint:	410 m2	Rainwater Storage Capacity:	12500L (5 x 2500L water tanks)
Floor Area (building):	386 m2	Household water appliances: (per dwelling)	5 x shower, basin, wc, kitch sink, laund tub, wm.

**Category 3:**  
**'Walk Up' Apartments**  
 Standard Industry Practice  
 10 Apartments (2 Levels)

- permeable surface - people
- permeable surface - car
- non-permeable surface
- non-permeable surface - usable
- deck / terrace
- garden
- garden - usable
- tree
- deep root zone
- capture
- store
- infiltrate (full)
- infiltrate (partial)



context plan 1/1000



Site Data			
Site Area:	1025 m2	Permeable Hard Surface:	0 m2
Number of Lots:	1	Non Permeable Hard Surface:	495 m2
Number of Dwellings:	10	Vegetated Surface:	27 m2
Density:	98 dwellings per hectare	Deep Root Zones:	1 (27 m2)
Open Space:	513 m2	Canopy Trees	1
Site Coverage:	46%	Additional On-Site Water Storage:	none

**Category 3:**  
**'Walk Up' Apartments**  
 Standard Industry Practice  
 10 Apartments (2 Levels)

- permeable surface - people
- permeable surface - car
- non-permeable surface
- non-permeable surface - usable
- deck / terrace
- garden
- garden - usable
- tree
- deep root zone
- capture
- store
- infiltrate (full)
- infiltrate (partial)

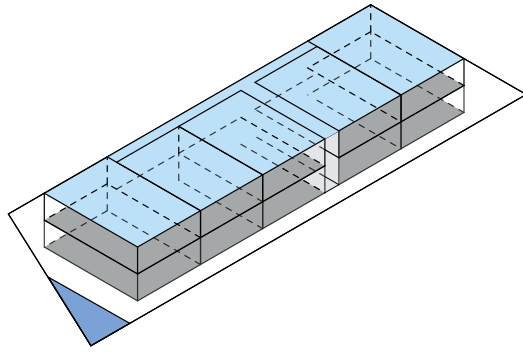

**axo (water)**

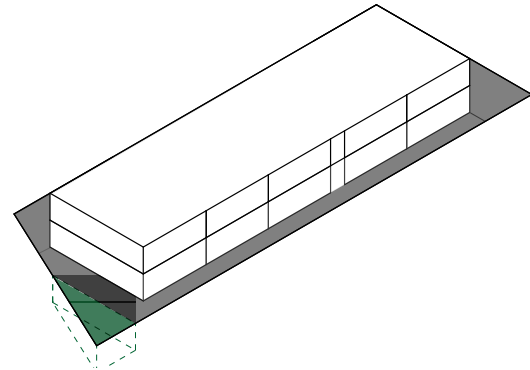

**axo (landscape)**

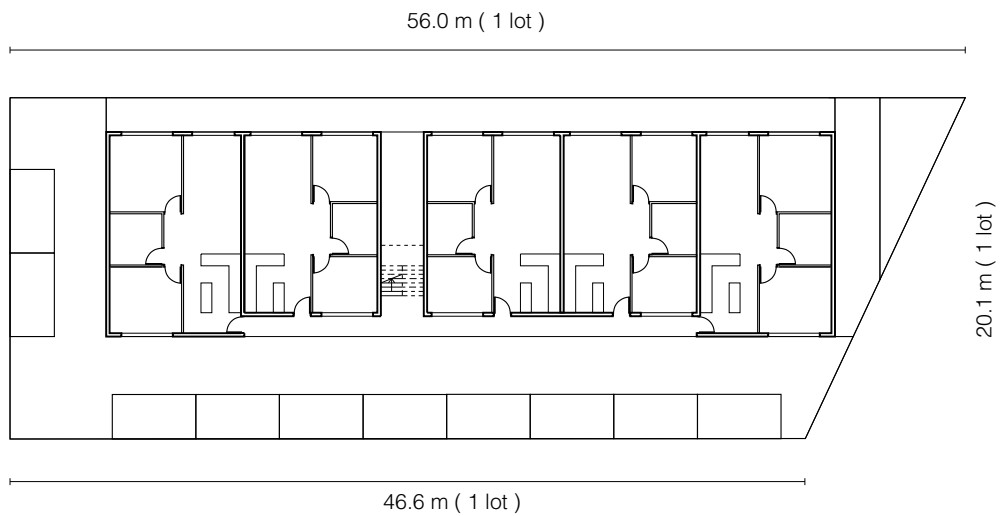

**plan 1 / 500**

<b>Dwelling Data:</b>			
Bedrooms:	2 (per dwelling)	Floor Area (deck):	0 m2 (all dwellings)
Occupants:	2 to 4 (per dwelling)	Garden Area:	27 m2 (all dwellings)
Cars:	10	Roof Surface Area:	512 m2 (all dwellings)
Building Storeys:	2	% of roof area connected to rainwater storage:	0%
Building Footprint:	512 m2	Rainwater Storage Capacity:	10000L (10 x 1000L water tanks)
Floor Area (building):	980 m2	Household water appliances: (per dwelling)	10 x shower, basin, wc, kitch sink, laund tub, wm.

**Category 3:**  
**'Walk Up' Apartments**  
 Water Sensitive Design 1  
 Gertrude St Apartments  
 Monash University 2012

- permeable surface - people
- permeable surface - car
- non-permeable surface
- non-permeable surface - usable
- deck / terrace
- garden
- garden - usable
- tree
- deep root zone
- capture
- store
- infiltrate (full)
- infiltrate (partial)



context plan 1/1000



Site Data			
Site Area:	1025 m2	Permeable Hard Surface:	189 m2
Number of Lots:	1	Non Permeable Hard Surface:	249 m2
Number of Dwellings:	8	Vegetated Surface:	255 m2
Density:	78 dwellings per hectare	Deep Root Zones:	10 (189 m2)
Open Space:	705 m2	Canopy Trees	up to 15
Site Coverage:	31%	Additional On-Site Water Storage:	Rain garden



**Category 3:**  
**'Walk Up' Apartments**  
 Water Sensitive Design 1  
 Gertrude St Apartments  
 Monash University 2012

- permeable surface - people
- permeable surface - car
- non-permeable surface
- non-permeable surface - usable
- deck / terrace
- garden
- garden - usable
- tree
- deep root zone
- capture
- store
- infiltrate (full)
- infiltrate (partial)

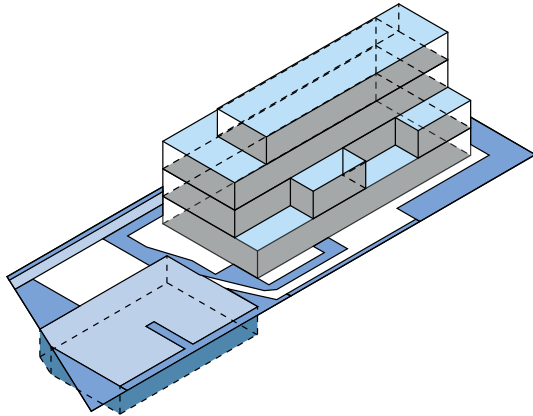

**axo (water)**

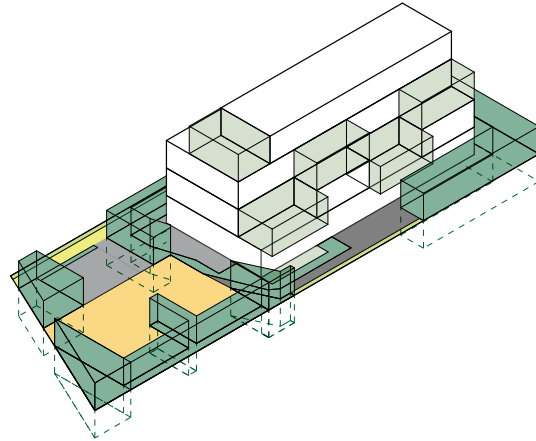

**axo (landscape)**

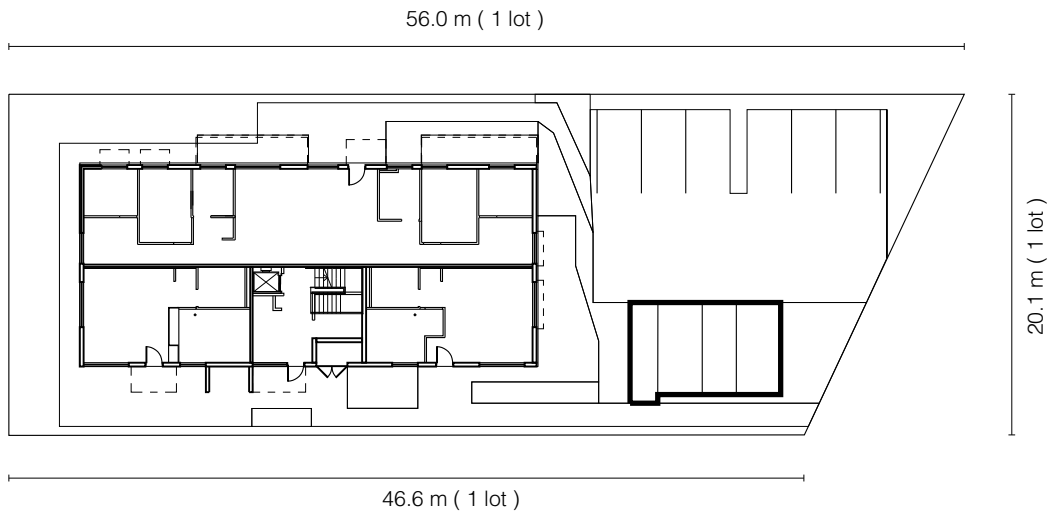

**plan 1 / 500**

<b>Dwelling Data:</b>			
Bedrooms:	1 to 4 (per dwelling)	Floor Area (deck):	140 m <sup>2</sup> (all dwellings)
Occupants:	1 to 4 (per dwelling)	Garden Area:	255 m <sup>2</sup> (all dwellings)
Cars:	8	Roof Surface Area:	244 m <sup>2</sup> (all dwellings)
Building Storeys:	4	% of roof area connected to rainwater storage:	100%
Building Footprint:	320 m <sup>2</sup>	Rainwater Storage Capacity:	20000L
Floor Area (building):	770 m <sup>2</sup>	Household water appliances: (per dwelling)	8 x shower, basin, wc, kitch sink, laund tub, wm.

**Category 3:**  
**'Walk Up' Apartments**  
 Water Sensitive Design 2  
 Gertrude St Apartments  
 Monash University 2012

- permeable surface - people
- permeable surface - car
- non-permeable surface
- non-permeable surface - usable
- deck / terrace
- garden
- garden - usable
- tree
- deep root zone
- capture
- store
- infiltrate (full)
- infiltrate (partial)



context plan 1/1000



Site Data			
Site Area:	1025 m2	Permeable Hard Surface:	44 m2
Number of Lots:	1	Non Permeable Hard Surface:	438 m2
Number of Dwellings:	7	Vegetated Surface:	306 m2
Density:	68 dwellings per hectare	Deep Root Zones:	4 (261 m2)
Open Space:	787 m2	Canopy Trees	up to 13
Site Coverage:	23%	Additional On-Site Water Storage:	Rain garden

**Category 3:**  
**'Walk Up' Apartments**  
 Water Sensitive Design 2  
 Gertrude St Apartments  
 Monash University 2012

- permeable surface - people
- permeable surface - car
- non-permeable surface
- non-permeable surface - usable
- deck / terrace
- garden
- garden - usable
- tree
- deep root zone
- capture
- store
- infiltrate (full)
- infiltrate (partial)

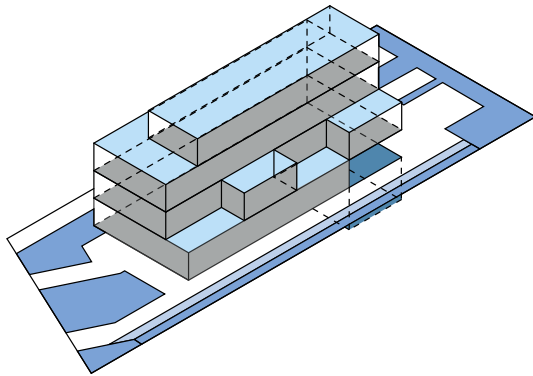

**axo (water)**

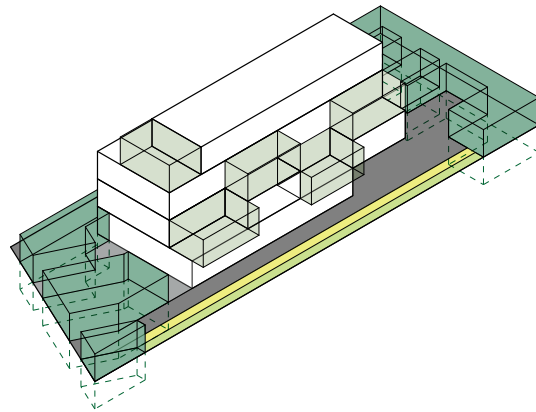

**axo (landscape)**

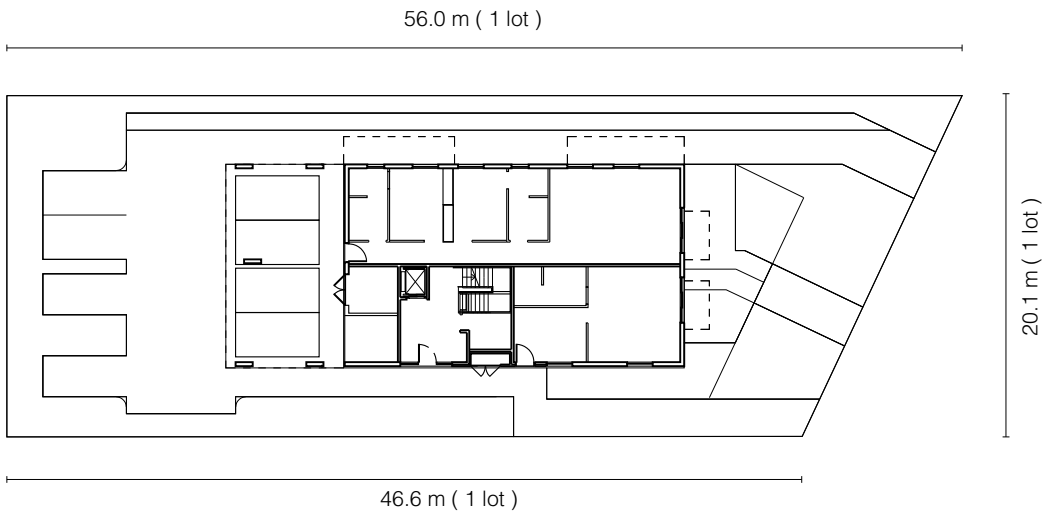

**plan 1 / 500**

<b>Dwelling Data:</b>			
Bedrooms:	1 to 4 (per dwelling)	Floor Area (deck):	140 m <sup>2</sup> (all dwellings)
Occupants:	1 to 4 (per dwelling)	Garden Area:	306 m <sup>2</sup> (all dwellings)
Cars:	8	Roof Surface Area:	244 m <sup>2</sup> (all dwellings)
Building Storeys:	4	% of roof area connected to rainwater storage:	100%
Building Footprint:	238 m <sup>2</sup>	Rainwater Storage Capacity:	20000L
Floor Area (building):	672 m <sup>2</sup>	Household water appliances: (per dwelling)	7 x shower, basin, wc, kitch sink, laund tub, wm.

### Category 3: 'Walk Up' Apartments

Redcliffe Connect  
Monash University &  
University of Western Australia, 2017

- permeable surface - people
- permeable surface - car
- non-permeable surface
- non-permeable surface - usable
- deck / terrace
- garden
- garden - usable
- tree
- deep root zone
- capture
- store
- infiltrate (full)
- infiltrate (partial)

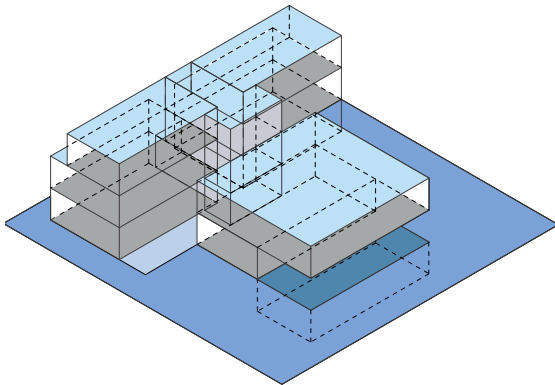

axo (water)

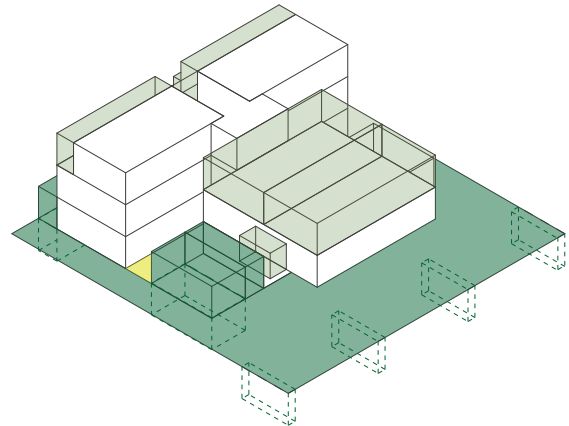

axo (landscape)

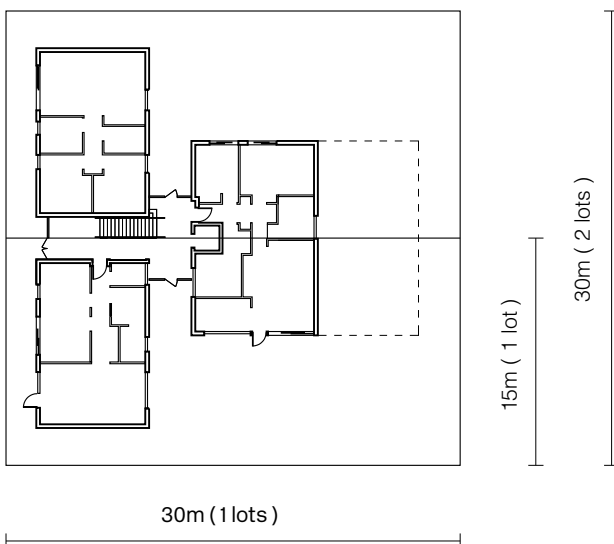

plan 1 / 500

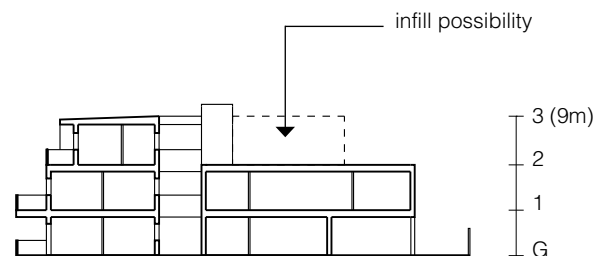

section 1 / 500

Dwelling Data:			
Bedrooms:	1, 2 and 3 (per dwelling)	Floor Area (deck):	110 m2 (all dwellings)
Occupants:	1 to 4 (per dwelling)	Garden Area:	200 m2 (all dwellings)
Cars:	12	Roof Surface Area:	294 m2 (all dwellings)
Building Storeys:	3	% of roof area connected to rainwater storage:	100%
Building Footprint:	276 m2	Rainwater Storage Capacity:	20000L
Floor Area (building):	662 m2	Household water appliances: (per dwelling)	9 x basin, wc, shower, kitch sink. 3 x laund tub, wm.

## **Category 4: Mid-rise apartment buildings**

Within the infill context, apartment buildings are medium-rise constructions, typically three to five storeys high, situated on two or more consolidated lots, with up to 20 strata-titled units, achieving density of 60 to 100 dwellings per hectare. Each apartment is typically accessed through shared hallways via stairs and lifts and has a designated private outdoor space in the form of a balcony or a terrace, in addition to a communal outdoor space. The grouped parking and storage areas are commonly located on the ground floor or in the basement, to maximise usable outdoor space. There is a variety of communal outdoor space uses (shared barbeque and seating areas are common), which opens more possibilities to implement water sensitive design solutions.

A variation of this type is a mixed-use apartment typology, with retail and offices on the ground floor adjacent to the main street, and residential units above. This model is more prevalent in areas closer to transportation and commercial nodes, and works well adjacent to well-designed public outdoor spaces, such as linear and street parks.

# Category 4: Mid-rise Apartment Buildings

Existing Suburban Condition  
Knutsford, WA

(Based on Hanover St Apartments, Fitzroy)

- permeable surface - people
- permeable surface - car
- non-permeable surface
- non-permeable surface - usable
- deck / terrace
- garden
- garden - usable
- tree
- deep root zone
- capture
- store
- infiltrate (full)
- infiltrate (partial)

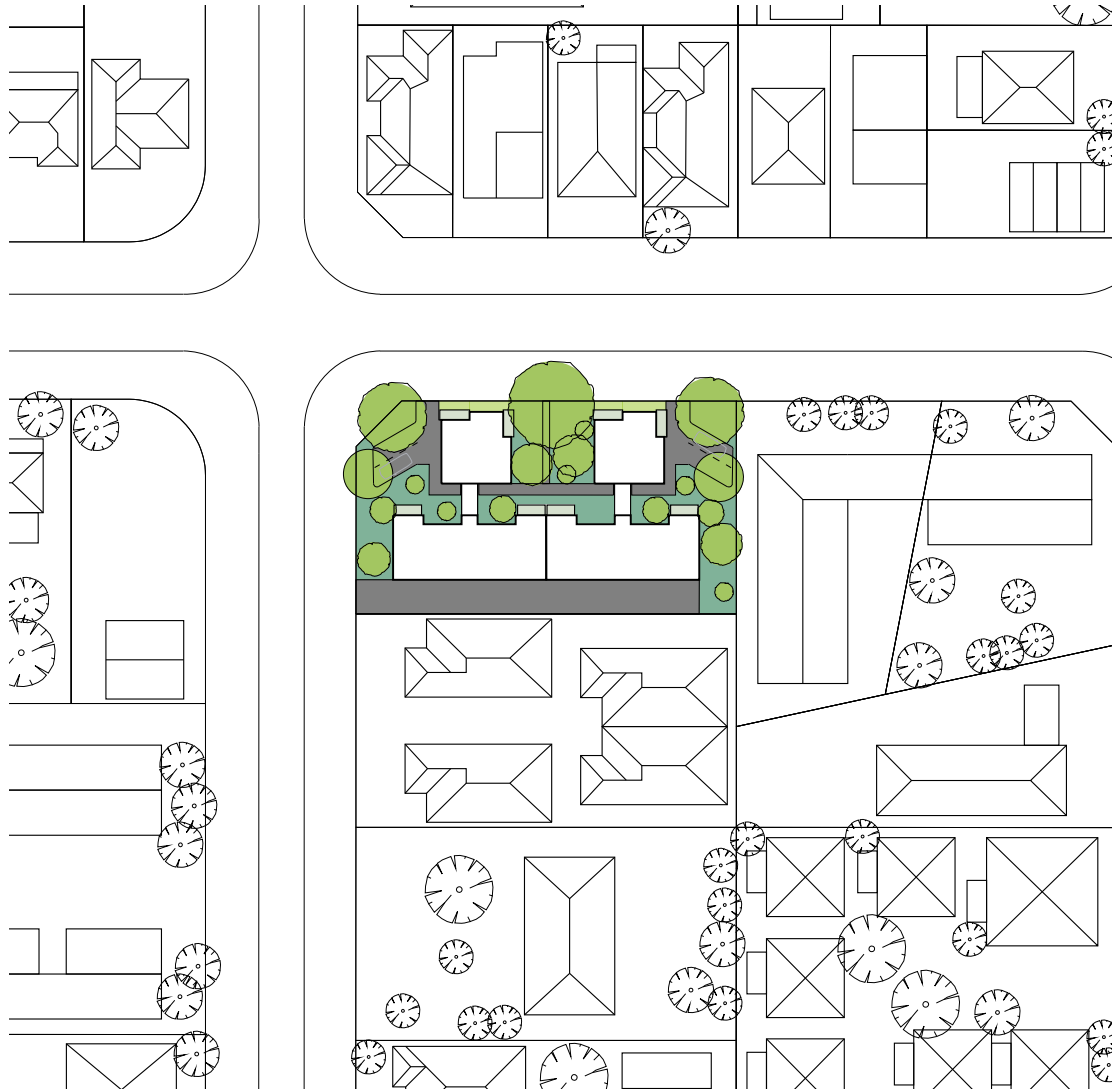

context plan 1/1000

<b>Site Data</b>			
Site Area:	1398 m2	Permeable Hard Surface:	0 m2
Number of Lots:	1	Non Permeable Hard Surface:	378 m2
Number of Dwellings:	18	Vegetated Surface:	524 m2
Density:	129 dwellings per hectare	Deep Root Zones:	4 (524 m2)
Open Space:	902 m2	Canopy Trees	9+
Site Coverage:	35%	Additional On-Site Water Storage:	none

## Category 4: Mid-rise Apartment Buildings

Existing Suburban Condition  
Knutsford, WA

- permeable surface - people
- permeable surface - car
- non-permeable surface
- non-permeable surface - usable
- deck / terrace
- garden
- garden - usable
- tree
- deep root zone
- capture
- store
- infiltrate (full)
- infiltrate (partial)

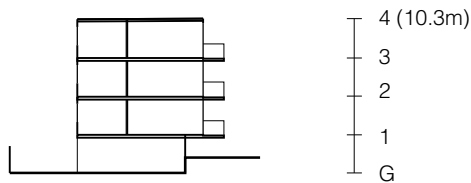

section 1 / 500

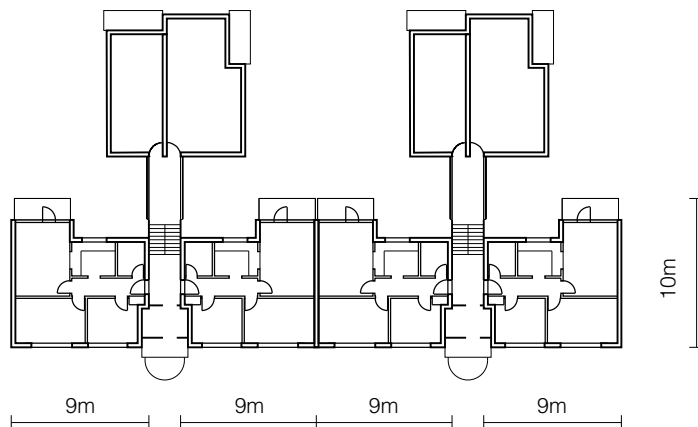

plan 1 / 500

<b>Dwelling Data:</b>			
Bedrooms:	2 (per dwelling)	Floor Area (deck):	40 m <sup>2</sup>
Occupants:	2-4 (per dwelling)	Garden Area:	524 m <sup>2</sup>
Cars:	1 (per dwelling)	Roof Surface Area:	496 m <sup>2</sup>
Building Storeys:	3	% of roof area connected to rainwater storage:	0%
Building Footprint:	480 m <sup>2</sup>	Rainwater Storage Capacity:	0 litres
Floor Area (building):	1275 m <sup>2</sup>	Household water appliances: (per dwelling)	1 x basin, wc, shower, 1 x laun tub, wm, kitch sink

**Category 4:**  
**Mid-rise Apartment Buildings**  
 Standard Industry Practice  
 Knutsford, WA

- permeable surface - people
- permeable surface - car
- non-permeable surface
- non-permeable surface - usable
- deck / terrace
- garden
- garden - usable
- tree
- deep root zone
- capture
- store
- infiltrate (full)
- infiltrate (partial)

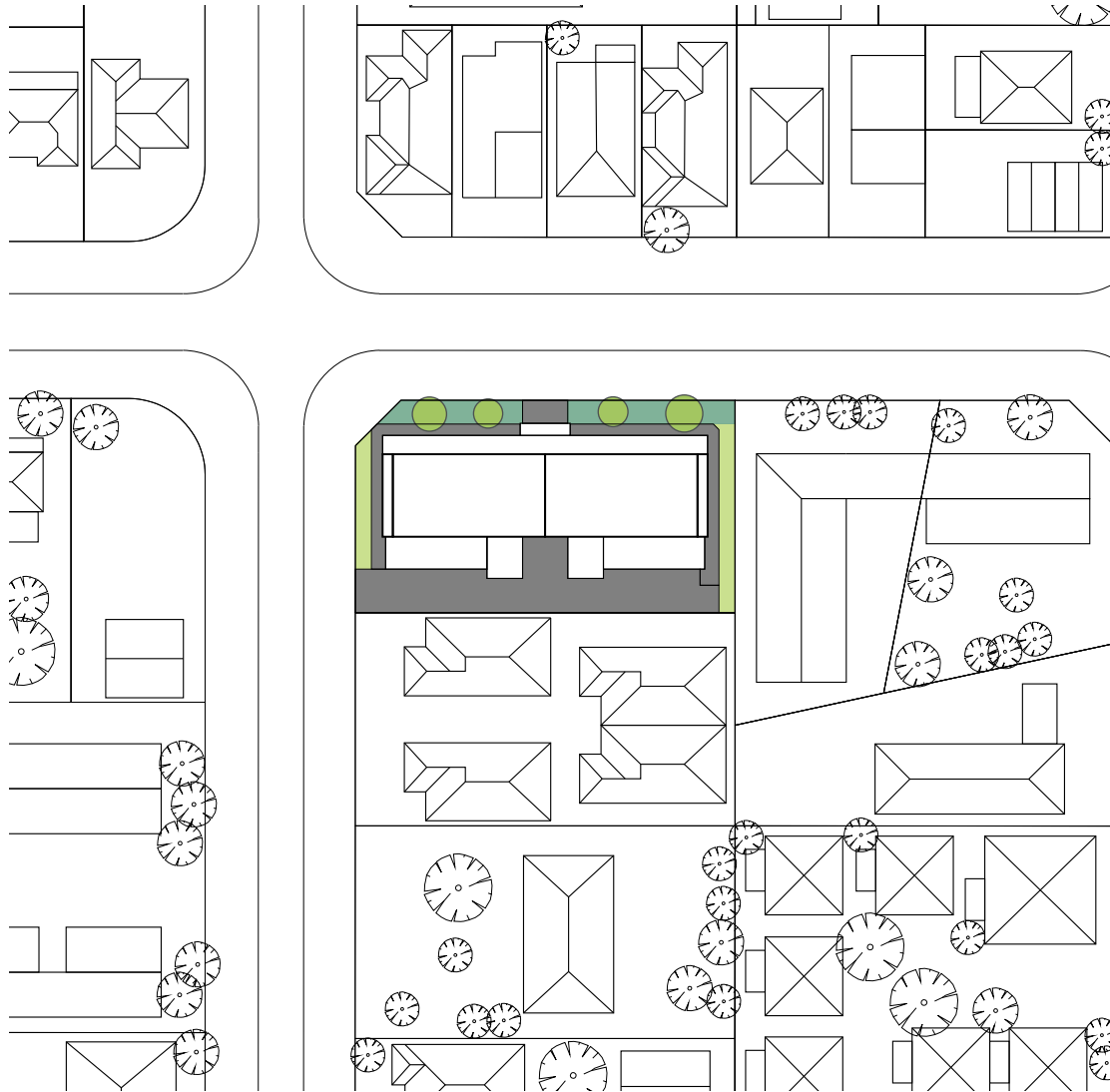

context plan 1/1000



<b>Site Data</b>			
Site Area:	1398 m2	Permeable Hard Surface:	0 m2
Number of Lots:	1	Non Permeable Hard Surface:	426 m2
Number of Dwellings:	11	Vegetated Surface:	217 m2
Density:	78 dwellings per hectare	Deep Root Zones:	2 (70 m2)
Open Space:	643 m2	Canopy Trees	4
Site Coverage:	55%	Additional On-Site Water Storage:	rain water tanks



**Category 4:**  
**Mid-rise Apartment Buildings**  
 Standard Industry Practice  
 Knutsford, WA

- permeable surface - people
- permeable surface - car
- non-permeable surface
- non-permeable surface - usable
- deck / terrace
- garden
- garden - usable
- tree
- deep root zone
- capture
- store
- infiltrate (full)
- infiltrate (partial)

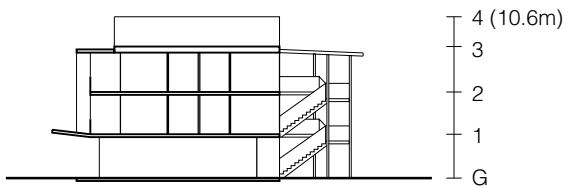

**section 1 / 500**

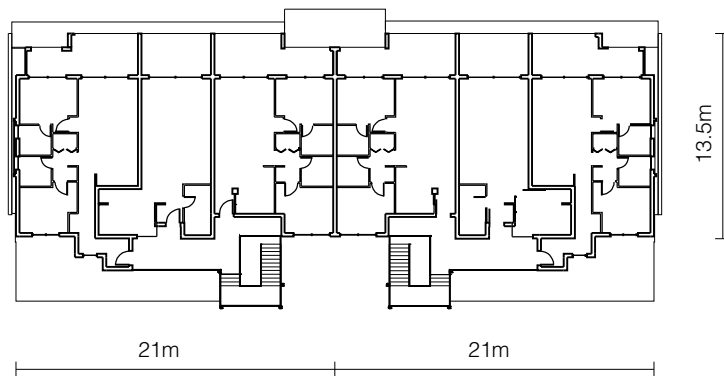

**plan 1 / 500**

<b>Dwelling Data:</b>			
Bedrooms:	1-2 (per dwelling)	Floor Area (deck):	348 m2
Occupants:	2-4 (per dwelling)	Garden Area:	217 m2
Cars:	1 (per dwelling)	Roof Surface Area:	755 m2
Building Storeys:	3	% of roof area connected to rainwater storage:	0%
Building Footprint:	755 m2	Rainwater Storage Capacity:	0 litres
Floor Area (building):	906 m2	Household water appliances: (per dwelling)	2 x basin, wc, shower, 1 x laun tub, wm, kitch sink

# Category 4: Mid-rise Apartment Buildings

Water Sensitive Design  
Knutsford, WA

- permeable surface - people
- permeable surface - car
- non-permeable surface
- non-permeable surface - usable
- deck / terrace
- garden
- garden - usable
- tree
- deep root zone
- capture
- store
- infiltrate (full)
- infiltrate (partial)

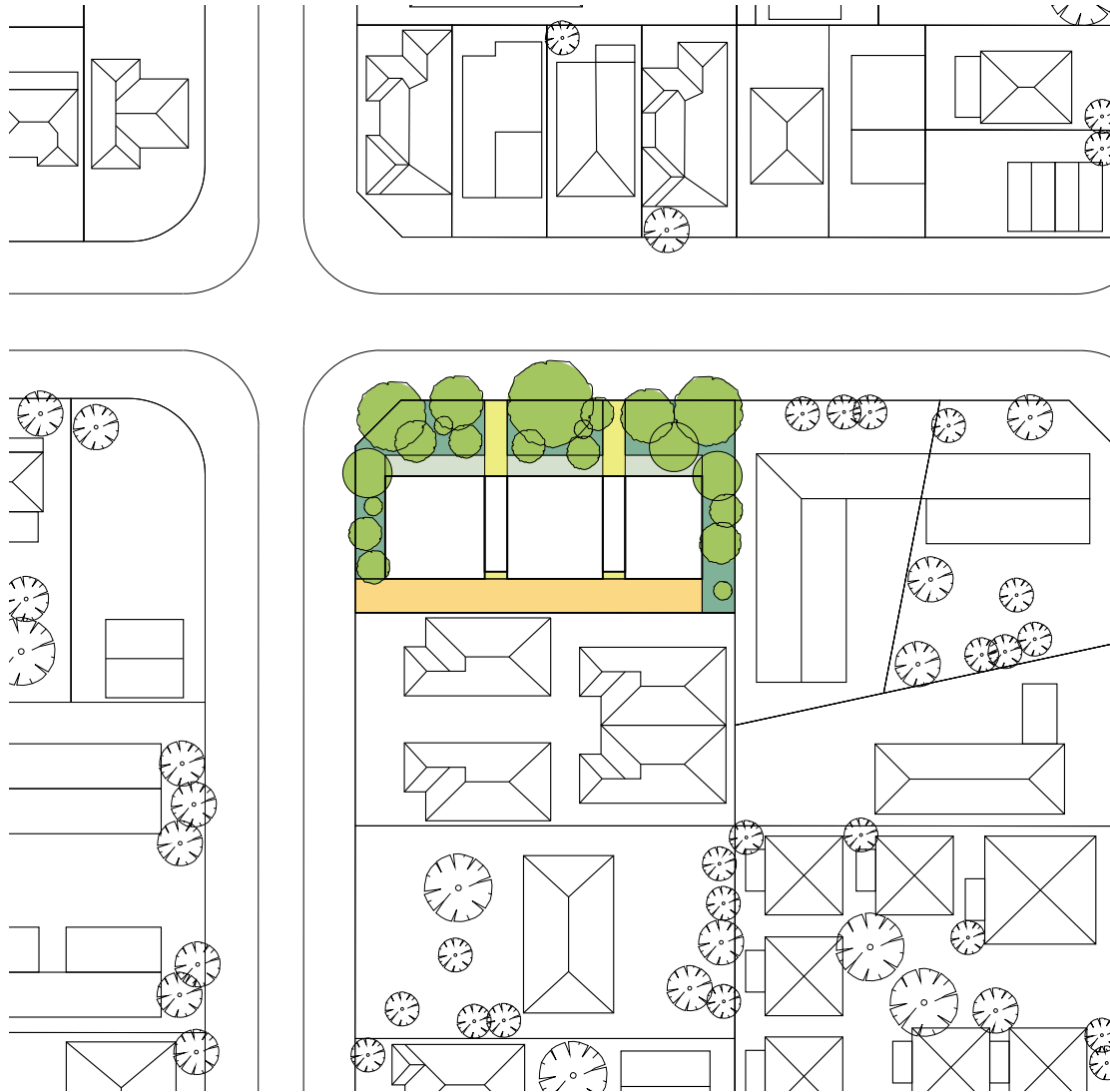

context plan 1/1000



Site Data			
Site Area:	1398 m2	Permeable Hard Surface:	272 m2
Number of Lots:	1	Non Permeable Hard Surface:	0 m2
Number of Dwellings:	14	Vegetated Surface:	523 m2
Density:	100 dwellings per hectare	Deep Root Zones:	3 (523 m2)
Open Space:	866 m2	Canopy Trees	12+
Site Coverage:	38%	Additional On-Site Water Storage:	communal capture & storage

**Category 4:**  
**Mid-rise Apartment Buildings**  
 Water Sensitive Design  
 Knutsford, WA

- permeable surface - people
- permeable surface - car
- non-permeable surface
- non-permeable surface - usable
- deck / terrace
- garden
- garden - usable
- tree
- deep root zone
- capture
- store
- infiltrate (full)
- infiltrate (partial)

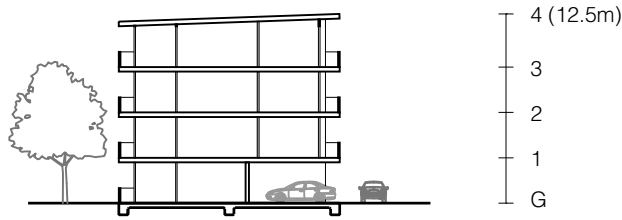

**section 1 / 500**

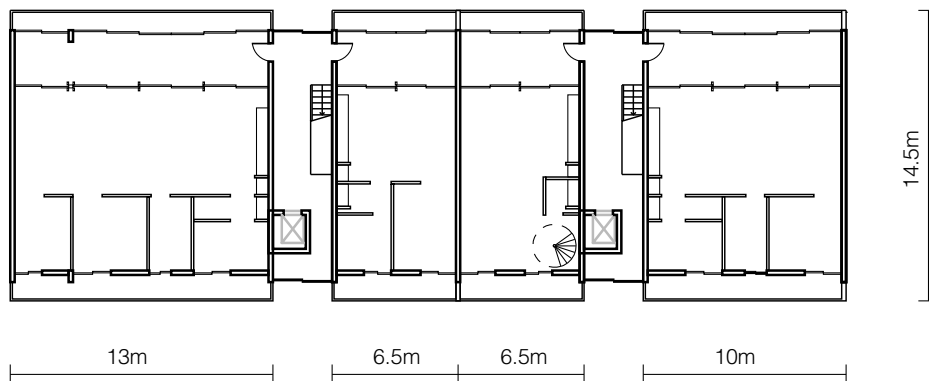

**plan 1 / 500**

<b>Dwelling Data:</b>			
Bedrooms:	1-3 (per dwelling)	Floor Area (deck):	179 m2
Occupants:	2-5 (per dwelling)	Garden Area:	523 m2
Cars:	1 (per dwelling)	Roof Surface Area:	755 m2
Building Storeys:	4	% of roof area connected to rainwater storage:	100%
Building Footprint:	830 m2	Rainwater Storage Capacity:	600,000 litres
Floor Area (building):	651 m2	Household water appliances: (per dwelling)	1 x basin, wc, shower, 1 x laun tub, wm, kitch sink

# Category 4: Mid-rise Apartment Buildings

Water Sensitive Design

Knutsford, WA

- permeable surface - people
- permeable surface - car
- non-permeable surface
- non-permeable surface - usable
- deck / terrace
- garden
- garden - usable
- tree
- deep root zone
- capture
- store
- infiltrate (full)
- infiltrate (partial)

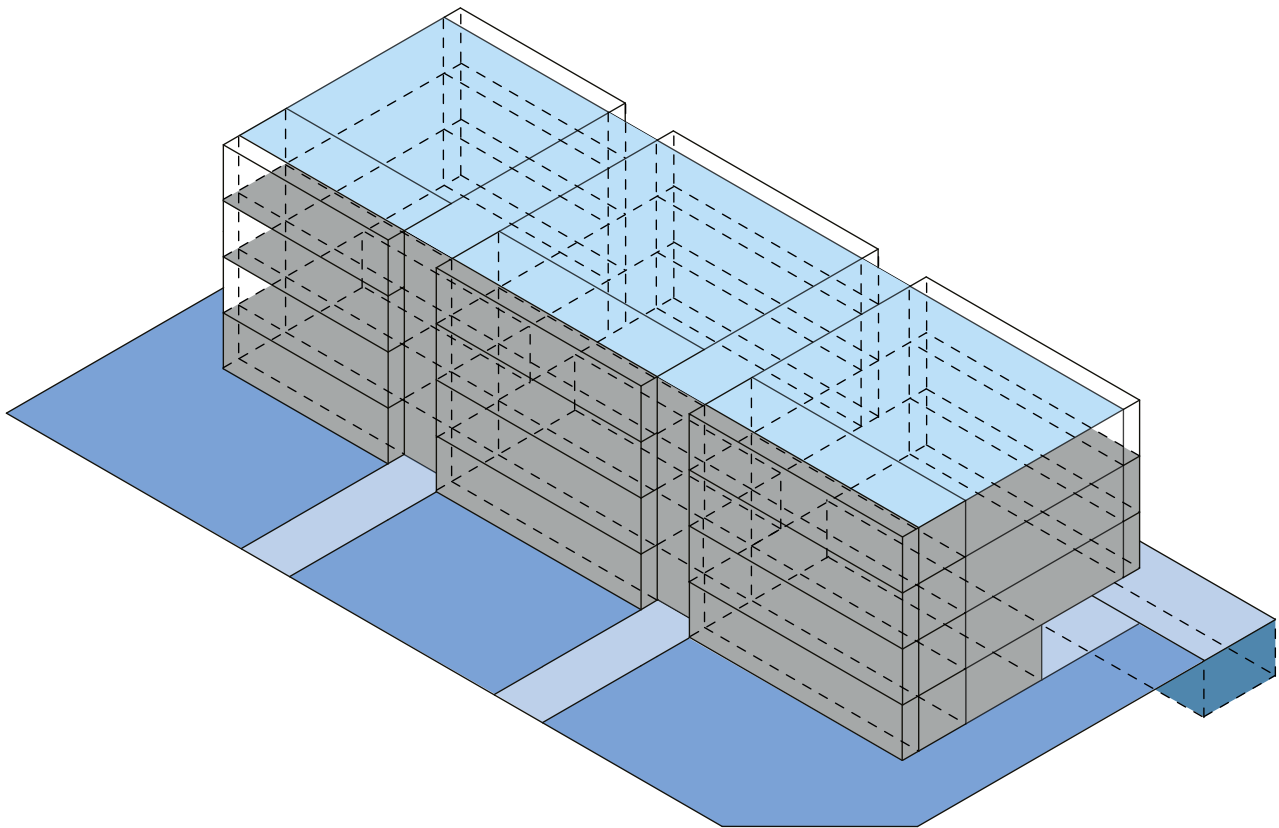

axo (water)

**Category 4:**  
**Mid-rise Apartment Buildings**  
 Water Sensitive Design  
 Knutsford, WA

- permeable surface - people
- permeable surface - car
- non-permeable surface
- non-permeable surface - usable
- deck / terrace
- garden
- garden - usable
- tree
- deep root zone
- capture
- store
- infiltrate (full)
- infiltrate (partial)

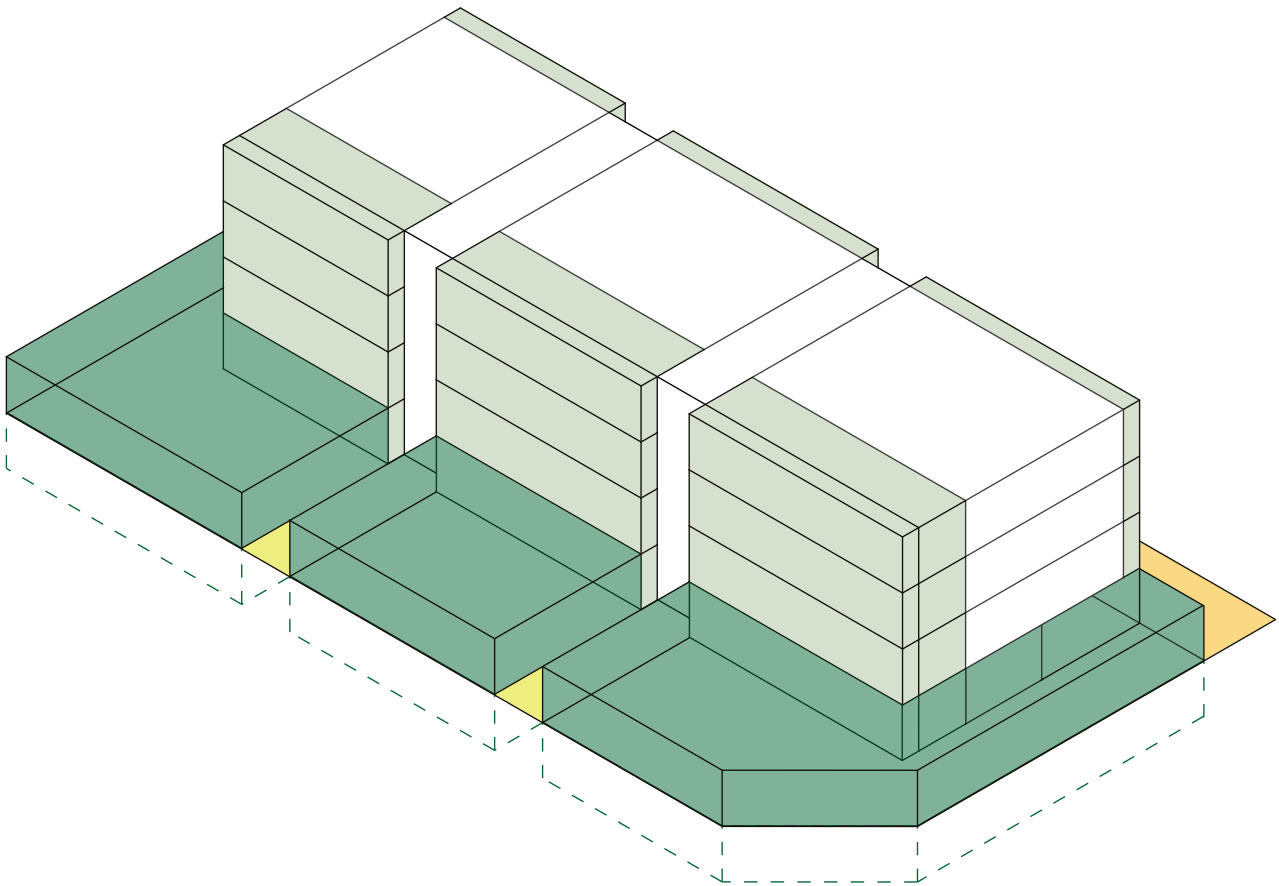

**axo (landscape)**

## Category 5: Urban spaces

The urban spaces category includes typical middle-ring suburban streets and laneways. Such streets are most commonly 15 to 20 metres wide, with generous crossovers and driveways, and minimal-width pedestrian paths often to only one side of the street. Exclusive bike paths are rare; it's more common to have bicycles share the road with cars. Water sensitive street design seeks appropriate landscaping and vegetation solutions and permeable surface treatments to increase infiltration and mitigate stormwater runoff, and to reduce urban heat island effects and encourage walkability. Considered placement and use of residential indoor and outdoor spaces can help activate street frontages and further encourage walkability.

Existing suburban laneways are between three and six metres wide and typically serve as access to private garages (rarely to a grouped parking space). Laneways generally have no verge and no deep soil area for planting, which results in sides solid with garage doors. Water sensitive urban design for laneways aims to collect stormwater, introduce greenery, and activate and connect to a wider pedestrian and cyclist network.

# Category 5: Urban Spaces

Suburban Street  
Existing Suburban Condition  
Essendon, VIC

- permeable surface - people
- permeable surface - car
- non-permeable surface
- non-permeable surface - usable
- deck / terrace
- garden
- garden - usable
- tree
- deep root zone
- capture
- store
- infiltrate (full)
- infiltrate (partial)



context plan 1/1000



<b>Site Data</b>			
Site Area:	2692 m2	Permeable Hard Surface:	0 m2
Number of Lots (adjacent):	16	Non Permeable Hard Surface:	2097 m2
Number of Dwellings (adjacent):	16	Vegetated Surface:	595 m2
Density:		Deep Root Zones:	15 (595 m2)
Open Space:	1301 m2 (road), 1391 m2 (non-road)	Canopy Trees	13+
Site Coverage:		Additional On-Site Water Storage:	None

# Category 5: Urban Spaces

Suburban Street  
Standard Industry Practice  
Cranbourne, VIC

- permeable surface - people
- permeable surface - car
- non-permeable surface
- non-permeable surface - usable
- deck / terrace
- garden
- garden - usable
- tree
- deep root zone
- capture
- store
- infiltrate (full)
- infiltrate (partial)



context plan 1/1000



Site Data			
Site Area:	2368 m2	Permeable Hard Surface:	0 m2
Number of Lots (adjacent):	22	Non Permeable Hard Surface:	1693 m2
Number of Dwellings (adjacent):	22	Vegetated Surface:	675 m2
Density:		Deep Root Zones:	20 ( 675 m2 )
Open Space:	1215 m2 (road), 1153 m2 (non-road)	Canopy Trees	23+
Site Coverage:		Additional On-Site Water Storage:	None



# Category 5: Urban Spaces

Suburban Street  
Water Sensitive Design  
Neeson Murcutt

- permeable surface - people
- permeable surface - car
- non-permeable surface
- non-permeable surface - usable
- deck / terrace
- garden
- garden - usable
- tree
- deep root zone
- capture
- store
- infiltrate (full)
- infiltrate (partial)

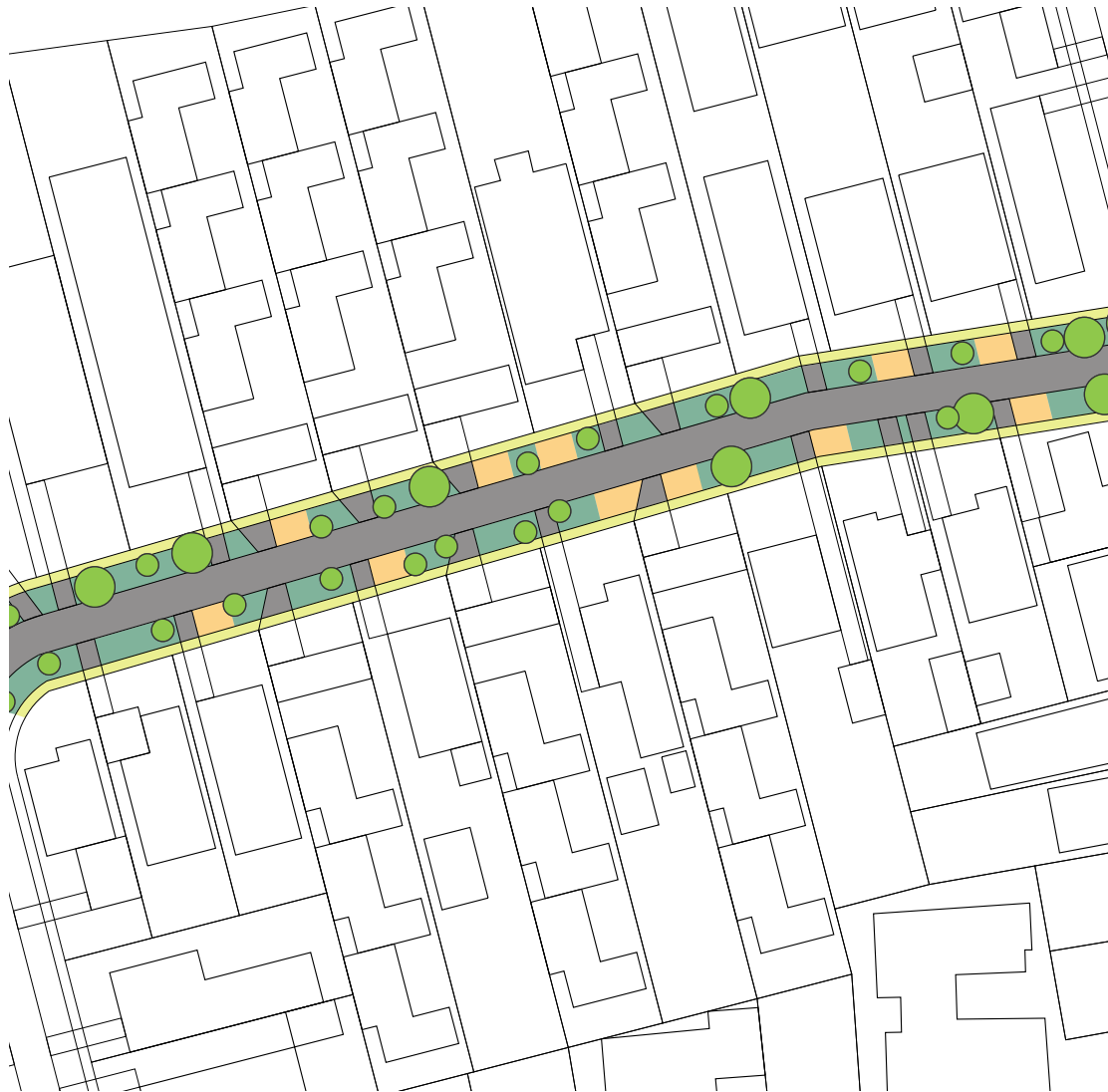

context plan 1/1000



<b>Site Data</b>			
Site Area:	2635 m2	Permeable Hard Surface:	670 m2
Number of Lots (adjacent):	24	Non Permeable Hard Surface:	983 m2
Number of Dwellings (adjacent):	24	Vegetated Surface:	712 m2
Density:		Deep Root Zones:	27 (712 m2)
Open Space:	758 m2 (road), 1877 m2 (non-road)	Canopy Trees	34
Site Coverage:		Additional On-Site Water Storage:	Communal water storage

# Category 5: Urban Spaces

Suburban Street  
Water Sensitive Design (Expanded)  
Neeson Murcutt

- permeable surface - people
- permeable surface - car
- non-permeable surface
- non-permeable surface - usable
- deck / terrace
- garden
- garden - usable
- tree
- deep root zone
- capture
- store
- infiltrate (full)
- infiltrate (partial)

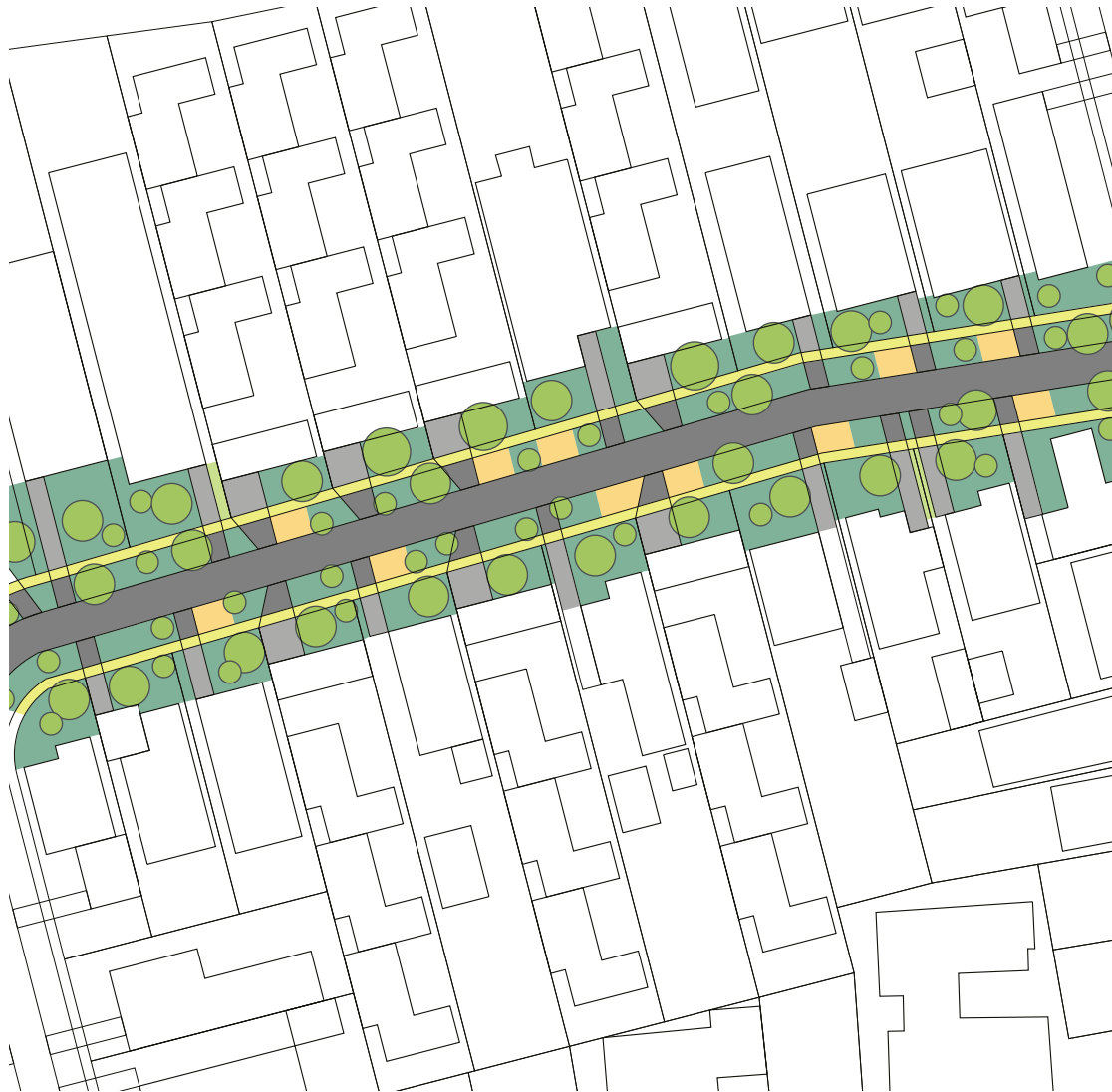

context plan 1/1000



Site Data			
Site Area:	4782 m2	Permeable Hard Surface:	670 m2
Number of Lots:	24	Non Permeable Hard Surface:	1439 m2
Number of Dwellings:	24	Vegetated Surface:	2380 m2
Density:		Deep Root Zones:	52 (2355 m2)
Open Space:	758 m2 (road), 4024 m2 (non-road)	Canopy Trees	70+
Site Coverage:		Additional On-Site Water Storage:	Communal / individual water storage

## Category 5: Urban Spaces

Suburban Laneway

Existing Suburban Condition

Carlton North

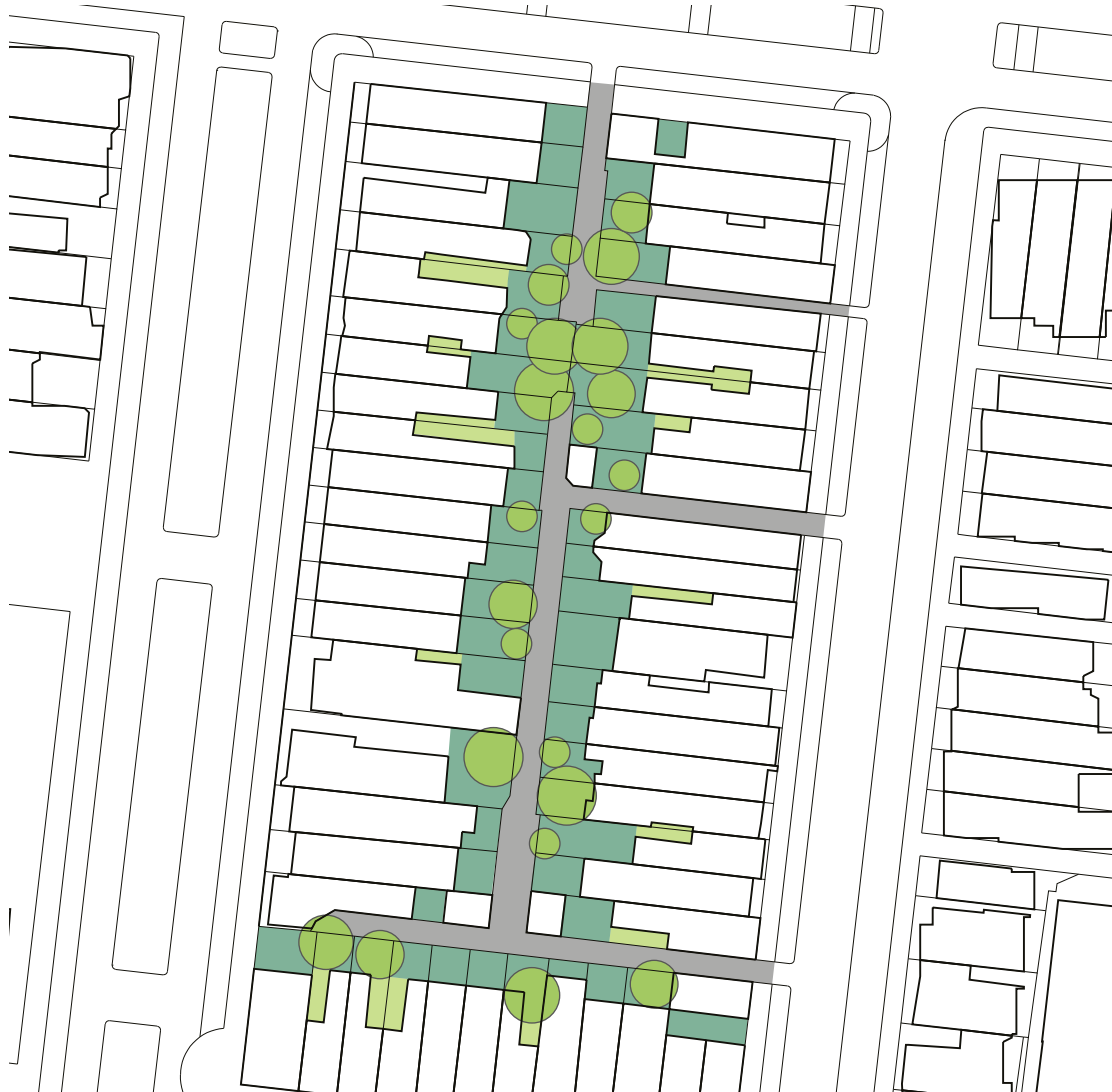
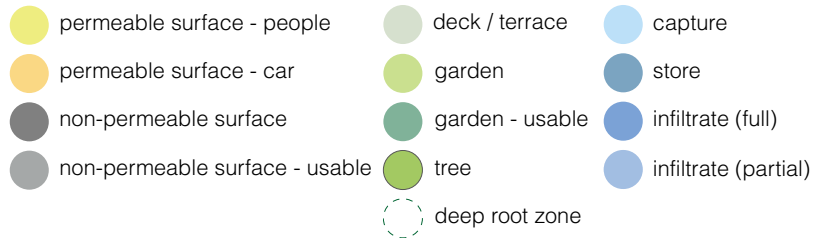

context plan 1/1000



Site Data			
Site Area:	2808 m2	Permeable Hard Surface:	0 m2
Number of Lots (adjacent):	49	Non Permeable Hard Surface:	740 m2
Number of Dwellings (adjacent):	49	Vegetated Surface:	2110 m2
Density:		Deep Root Zones:	10 (1857 m2)
Open Space:	567 m2 (road), 2241 m2 (non-road)	Canopy Trees	23+
Site Coverage:		Additional On-Site Water Storage:	None

# Category 5: Urban Spaces

Suburban Laneway  
Standard Industry Practice  
Cranbourne

- permeable surface - people
- permeable surface - car
- non-permeable surface
- non-permeable surface - usable
- deck / terrace
- garden
- garden - usable
- tree
- deep root zone
- capture
- store
- infiltrate (full)
- infiltrate (partial)



context plan 1/1000



Site Data			
Site Area:	2368 m2	Permeable Hard Surface:	0 m2
Number of Lots (adjacent):	22	Non Permeable Hard Surface:	0 m2
Number of Dwellings (adjacent):	22	Vegetated Surface:	0 m2
Density:		Deep Root Zones:	0
Open Space:	0 m2 (road), 0 m2 (non-road)	Canopy Trees	0
Site Coverage:		Additional On-Site Water Storage:	None

# Category 5: Urban Spaces

Suburban Laneway

Water Sensitive Design

Knutsford, WA, Spaceagency

- permeable surface - people
- permeable surface - car
- non-permeable surface
- non-permeable surface - usable
- deck / terrace
- garden
- garden - usable
- tree
- deep root zone
- capture
- store
- infiltrate (full)
- infiltrate (partial)



context plan 1/1000



Site Data			
Site Area:	1632 m2	Permeable Hard Surface:	224 m2
Number of Lots (adjacent):	14	Non Permeable Hard Surface:	1060 m2
Number of Dwellings (adjacent):	40+	Vegetated Surface:	327 m2
Density:		Deep Root Zones:	12 (327 m2)
Open Space:	439 m2 (road), 1193 m2 (non-road)	Canopy Trees	11+
Site Coverage:		Additional On-Site Water Storage:	Unknown

## Category 6: Precincts

The precincts category involves large scale infill developments, most commonly a redevelopment of former industrial and other rezoned areas, on brownfield, greyfield or greenfield sites within or close to well-established suburban contexts. Sites available for precinct scale infill development can be consolidated or disaggregated, which affects the scale and reach of water sensitive design strategies. Consolidated precincts are more likely to incorporate a combination of several dwelling types and urban spaces, streets and laneways, and a variety of open public spaces, such as parks and squares. Consolidated precincts offer the opportunity to design well-connected, accessible and usable outdoor spaces (private, communal and public).

## Case study area: Salisbury Centre East

A key objective of the CRCWSC IRP4 research project is to test residential infill typologies that can achieve water sensitive outcomes. The team undertook this by evaluating the performance of different infill typologies at actual case study sites. One of the case study sites is the 'Salisbury Centre East' area within Salisbury City in Adelaide, South Australia. It is representative of a small scale, low to medium density infill development on scattered sites that include individual privately owned lots, a public housing site, industrial and vacant land. The total case study area is about 90 hectares, predominantly residential, with some commercial and industrial uses. It is close to the Salisbury town centre and has good access to public transport, with Salisbury train station nearby, and metro bus services passing through the precinct.

The population in the area is rapidly aging, and is of low to middle socioeconomic status. Existing housing stock consists of mainly three- and four-bedroom detached modest homes on large blocks, or unit developments surrounded by generously proportioned private green space. Median occupancy rates are two persons per dwelling, and the number of single- and two-person households in this area is expected to grow (Government of South Australia, 2017, p. 17, p.152). This suggests increased demand for a variety of housing forms, with two- and three-bedroom dwellings on smaller allotments of less than 150 square metres being the most popular.

The study area is in a 'first stage' of urban rejuvenation in accordance with the City of Salisbury Growth Action Plan. Salisbury Centre East, together with surrounding suburbs, is expected to yield an additional 2,500 new dwellings through urban consolidation (Government of South Australia, 2017, p. 140). Infill activity within the study area has commenced, and includes single dwelling replacement, dual occupancies, and unit and townhouse developments. But recent infill development is typified by unit and townhouse developments surrounded by highly impervious paving and devoid of any green space in common or private areas.

With Little Para River and Cobbler Creek passing through the area, Salisbury Centre East is a suitable precinct in which to explore innovative solutions for groundwater recharge and for broader urban renewal that includes water elements for greening, thermal comfort, public amenity and connectivity. This may include initiatives such as creek daylighting or integrating green corridors and spines within infill development. The case study area also includes a series of vegetated and non-vegetated laneways that have the potential to increase connectivity.

# Category 6:

## Precincts

Water Sensitive Precinct 1

Salisbury, SA

Monash University &

University Of Western Australia 2019

- permeable surface - people
- deck / terrace
- capture
- permeable surface - car
- garden
- store
- non-permeable surface
- garden - usable
- infiltrate (full)
- non-permeable surface - usable
- tree
- infiltrate (partial)
- deep root zone

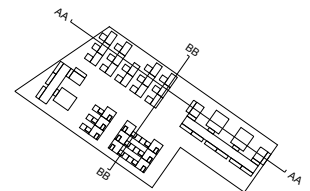
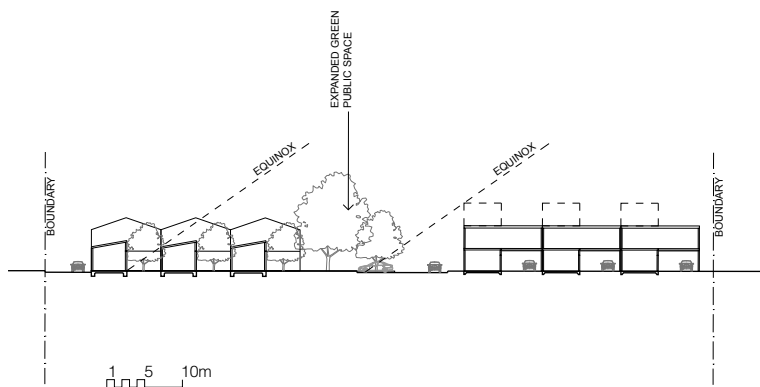
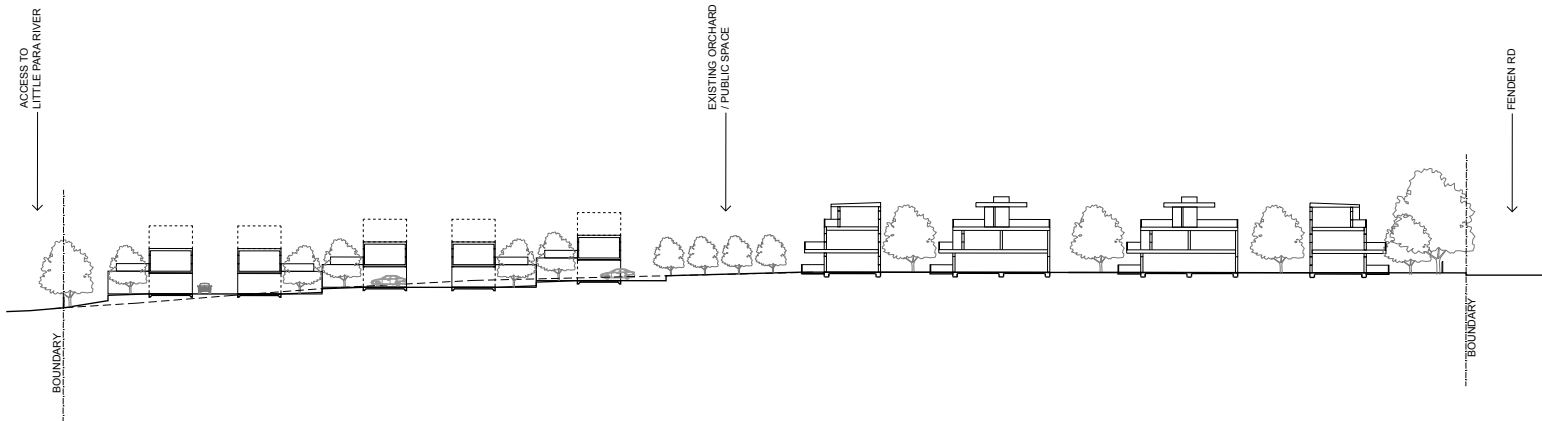

section 1/1000

<b>Site Data</b>			
Site Area:	13,840 m2	Permeable Hard Surface:	6034 m2
Number of Lots (adjacent):	3	Non Permeable Hard Surface:	0 m2
Number of Dwellings (adjacent):	68	Vegetated Surface:	4429 m2
Density:	49 dwellings per hectare	Deep Root Zones:	35
Open Space:	10,463 m2	Canopy Trees	60+
Site Coverage:	25%	Additional On-Site Water Storage:	Communal water storage





# Category 6:

## Precincts

Water Sensitive Precinct 2

Salisbury, SA

Monash University &

University Of Western Australia 2019

- permeable surface - people
- deck / terrace
- capture
- permeable surface - car
- garden
- store
- non-permeable surface
- garden - usable
- infiltrate (full)
- non-permeable surface - usable
- tree
- infiltrate (partial)
- deep root zone

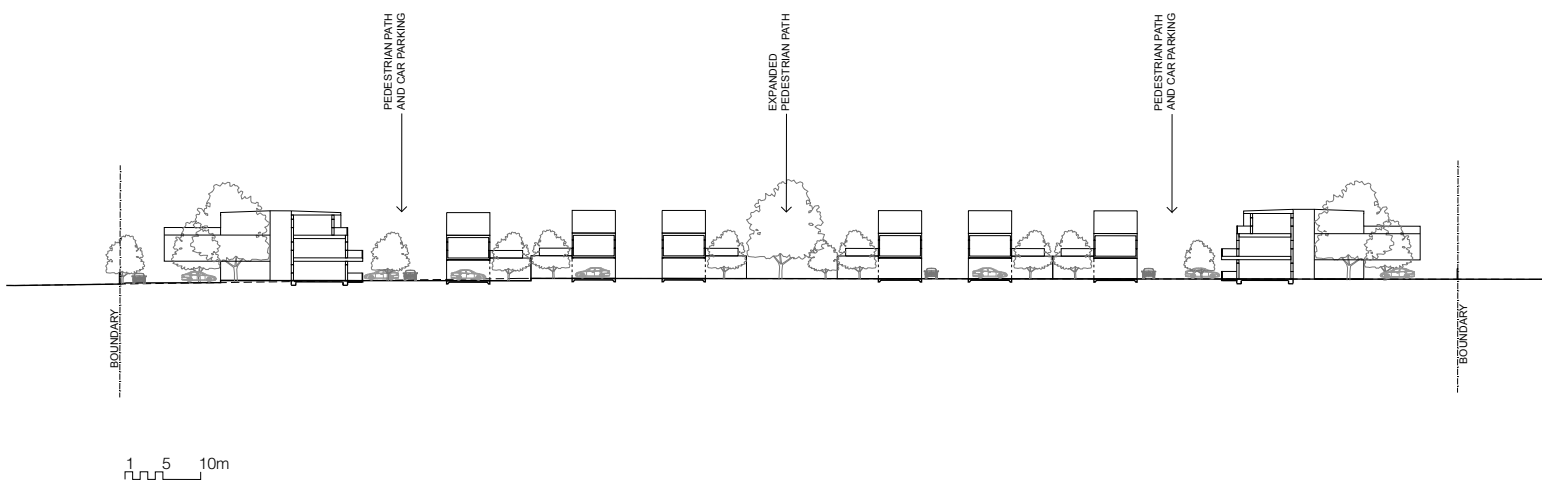

section 1/1000

Site Data			
Site Area:	? m2	Permeable Hard Surface:	? m2
Number of Lots (adjacent):	?	Non Permeable Hard Surface:	? m2
Number of Dwellings (adjacent):	?	Vegetated Surface:	? m2
Density:	? dwellings per hectare	Deep Root Zones:	?
Open Space:	? m2	Canopy Trees	?
Site Coverage:	? %	Additional On-Site Water Storage:	?



# Category 6:

## Precincts

Water Sensitive Precinct 3

Salisbury, SA

Monash University &

University Of Western Australia 2019

- permeable surface - people
  - permeable surface - car
  - non-permeable surface
  - non-permeable surface - usable
- deck / terrace
  - garden
  - garden - usable
  - tree
  - deep root zone
- capture
  - store
  - infiltrate (full)
  - infiltrate (partial)

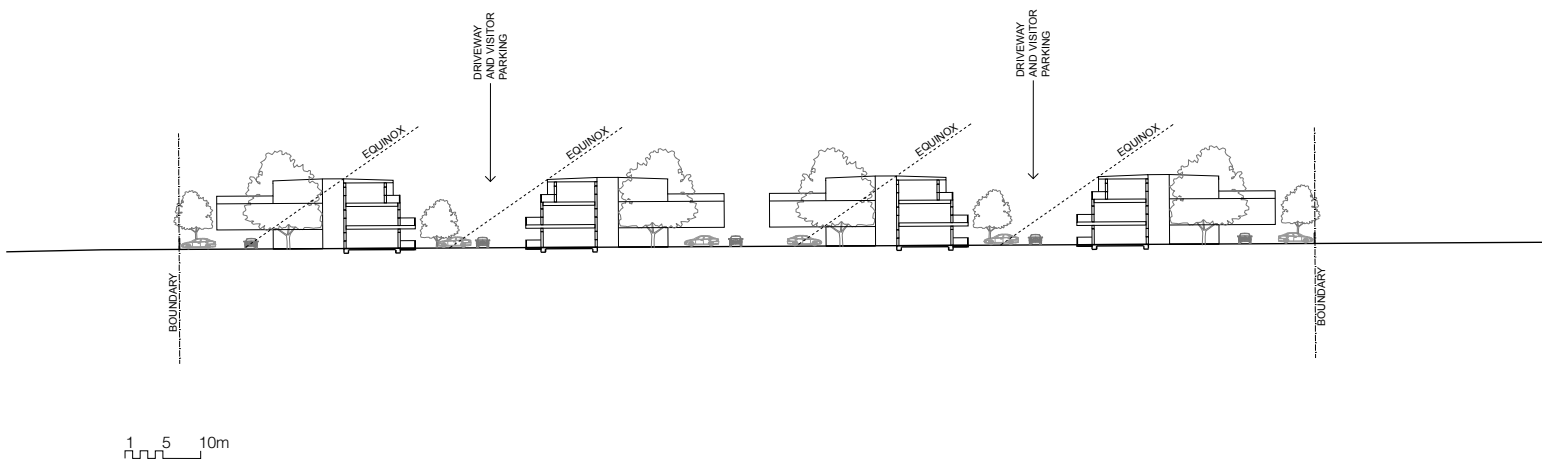

section 1/1000

<b>Site Data</b>			
Site Area:	? m2	Permeable Hard Surface:	? m2
Number of Lots (adjacent):	?	Non Permeable Hard Surface:	? m2
Number of Dwellings (adjacent):	?	Vegetated Surface:	? m2
Density:	? dwellings per hectare	Deep Root Zones:	?
Open Space:	? m2	Canopy Trees	?
Site Coverage:	? %	Additional On-Site Water Storage:	?

# Category 6:

## Precincts

Water Sensitive Precinct 4

Salisbury, SA

Monash University &

University Of Western Australia 2019

- permeable surface - people
- deck / terrace
- capture
- permeable surface - car
- garden
- store
- non-permeable surface
- garden - usable
- infiltrate (full)
- non-permeable surface - usable
- tree
- infiltrate (partial)
- deep root zone

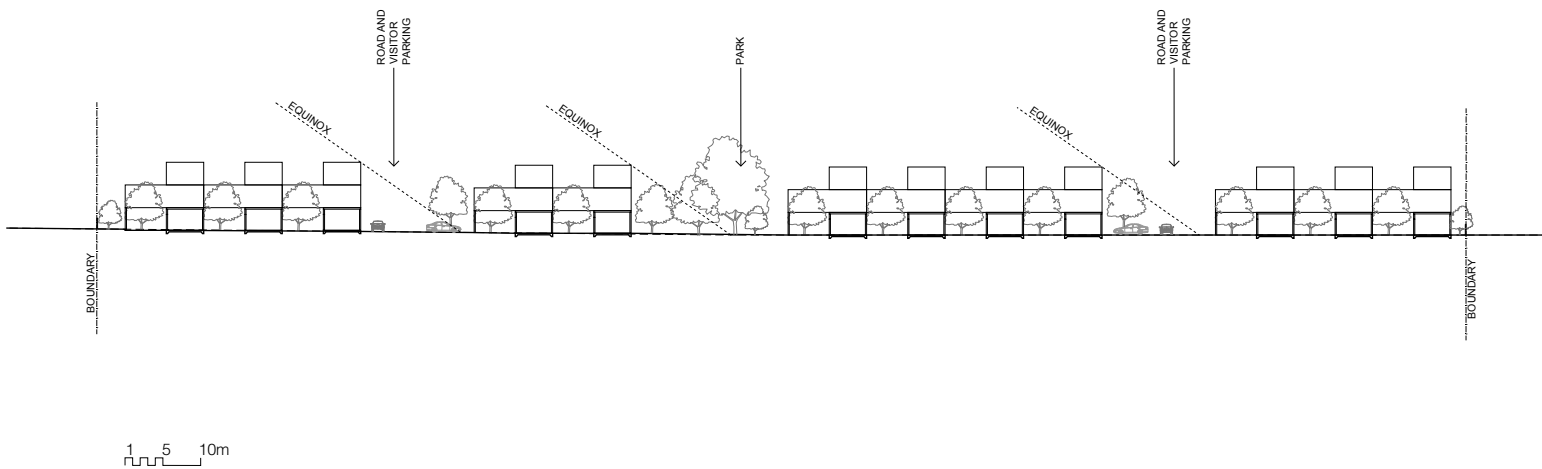

section 1/1000

<b>Site Data</b>			
Site Area:	? m2	Permeable Hard Surface:	? m2
Number of Lots (adjacent):	?	Non Permeable Hard Surface:	? m2
Number of Dwellings (adjacent):	?	Vegetated Surface:	? m2
Density:	? dwellings per hectare	Deep Root Zones:	?
Open Space:	? m2	Canopy Trees	?
Site Coverage:	? %	Additional On-Site Water Storage:	?





## Case study area: Knutsford Street Precinct, Fremantle

The Knutsford Street Precinct is within the City of Fremantle, the port of Perth in Western Australia. The City of Fremantle's current population is 32,000, and is expected to increase to 43,000 by 2038. The target residential infill development for Perth's central sub-region, of which Fremantle is part, is an additional 121,000 dwellings by 2031 (Western Australian Planning Commission, 2010, p. 25). Knutsford Street Precinct is strategically important to achieving this target since it contains 23 hectares of vacant, or soon to be vacant, industrial brownfield land. Of this, Development WA (the state government's land development agency) owns 10 hectares, and the City of Fremantle owns nine hectares. The case study area is a three hectare large block of former industrial land, currently owned by Development WA.

The area is surrounded by established residential areas featuring a mix of housing types, including individual houses, social housing apartment blocks, and recent strata-titled grouped housing infill developments. It caters for medium to high socioeconomic demographics, with a steady demand for mid density low-rise housing such as townhouses, courtyard houses and small apartment blocks. An important aspect of this case study is the proposed Knutsford Street Green Spine, using the street's very wide road reserve to create an enhanced public realm of parkland and recreational amenities. This development will encourage walkability and better connect the precinct.

The Knutsford Street Green Spine becomes a key component of water management, particularly for the regenerative management of groundwater aquifers (recharge, treatment, managed use) in a way that is specific to the Perth region. The water supply infrastructure for the future development needs to be upgraded to meet the demands and challenges of the location. The topography is characterised by shallow soils on a limestone ridge, with poor and unreliable drainage and a history of shallow groundwater contamination, high evapotranspiration in the predominately hot and dry climate, and lack of fit-for-purpose irrigation water for landscaping in the area.

The availability of a precinct scale study area provides the opportunity to explore water sensitive design solutions in the context of different densities and scales. It allows water-based evaluations at the scale of the individual lot, agglomerated lots, and the broader precinct area, all integrated with the Green Spine. The survey strata sub-divisions and future use of 'community titles' are an opportunity to explore innovative models for utilities on a financially viable precinct scale that are decentralised, shared and combined (for example, multi-utility services with innovative governance systems for water supply (rainwater and stormwater harvesting and recycling), energy (community battery), wastewater, and solid waste).

# Category 6: Precincts

Knutsford, WA  
Monash University &  
University Of Western Australia 2019

- permeable surface - people
- deck / terrace
- capture
- permeable surface - car
- garden
- store
- non-permeable surface
- garden - usable
- infiltrate (full)
- non-permeable surface - usable
- tree
- infiltrate (partial)
- deep root zone

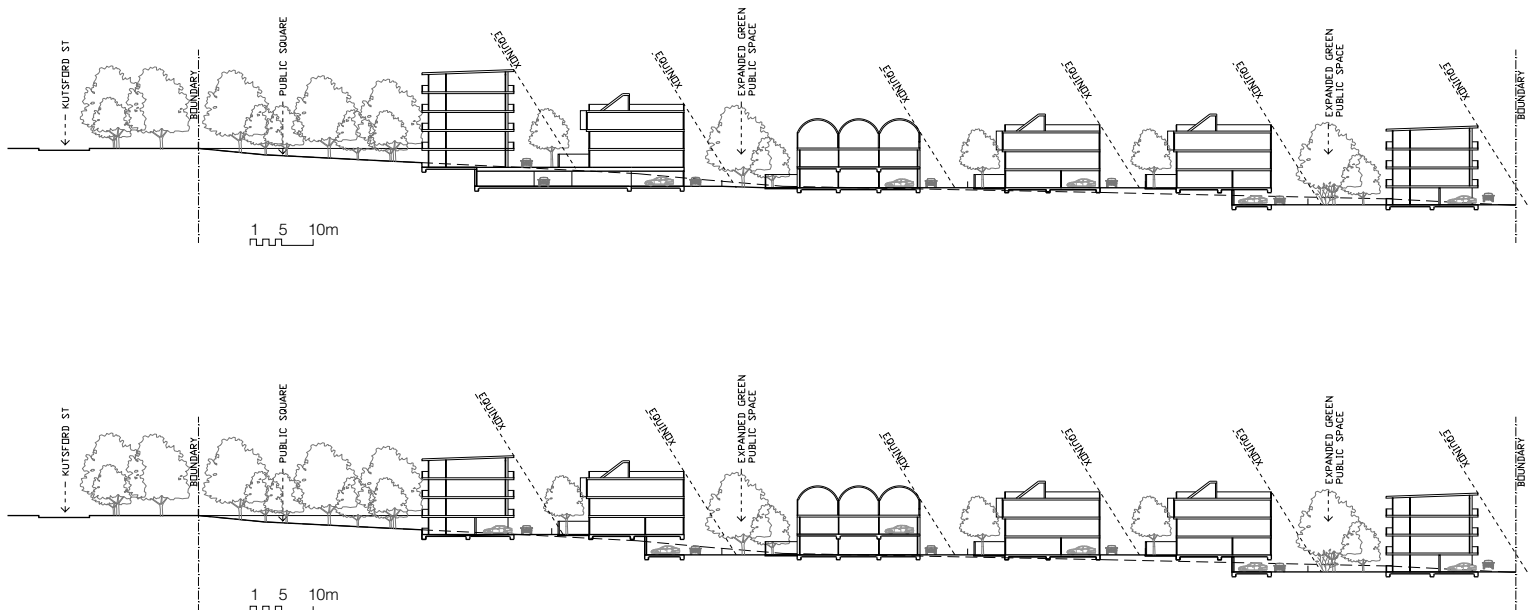

section 1/1000

<b>Site Data</b>			
Site Area:	30,100 m2	Permeable Hard Surface:	13,444 m2
Number of Lots (adjacent):	1	Non Permeable Hard Surface:	0 m2
Number of Dwellings (adjacent):	171	Vegetated Surface:	4802 m2
Density:	57 dwellings per hectare	Deep Root Zones:	40
Open Space:	18,246 m2	Canopy Trees	80+
Site Coverage:	39%	Additional On-Site Water Storage:	Communal water capture storage and re-use



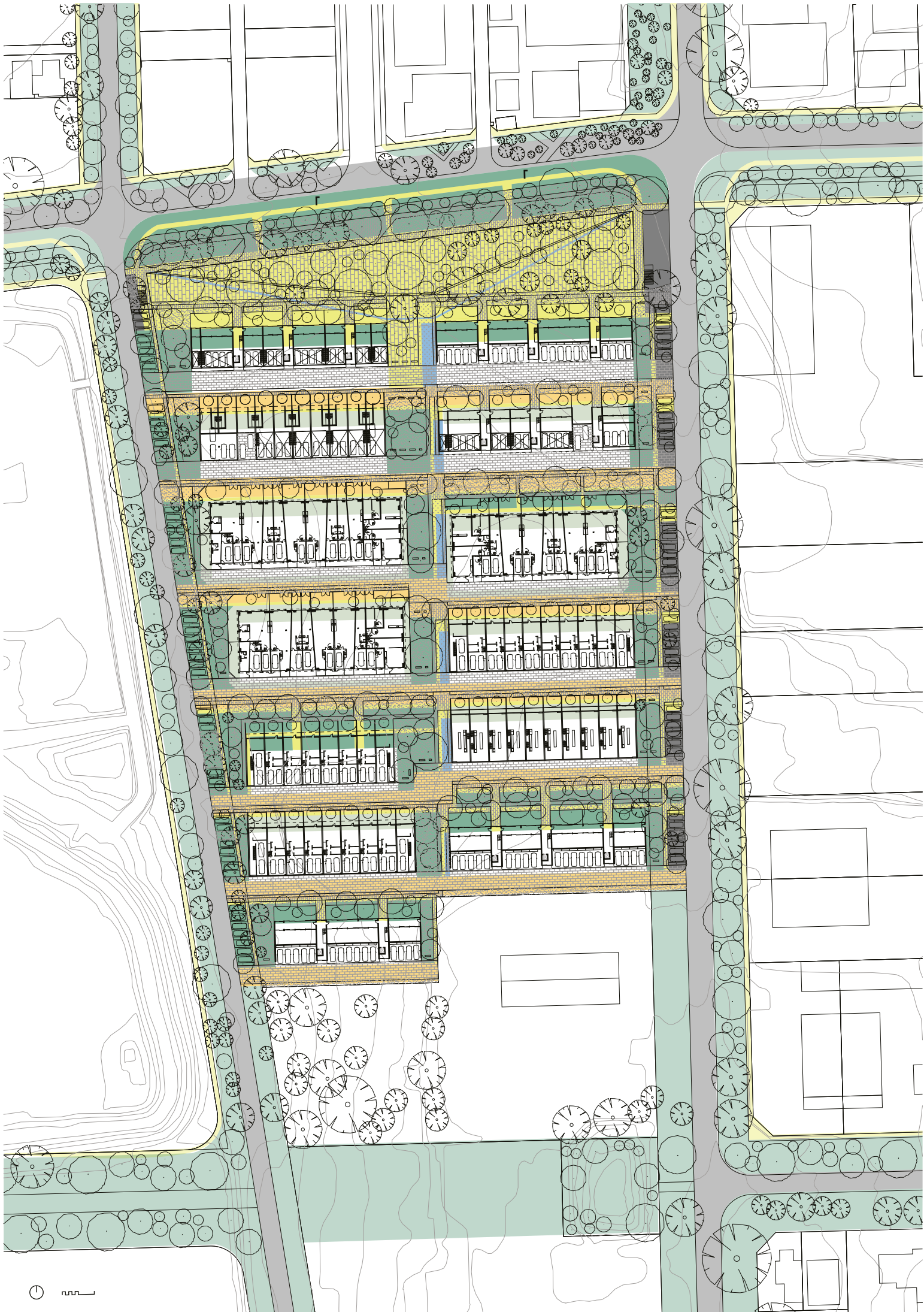

## Category 7: Building elements

This category refers to a collection of design elements or urban and architectural details that contribute to water sensitive urban design. As such, this collection further guides the analysis of urban and architectural qualities, illustrating specific characteristics described under four principal categories: amenity and function, and access to quality outdoor space (private, communal and public). For example, when analysing the quality of public outdoor space, active streetscape is one of the forming attributes, which is further illustrated with urban and architectural elements such as front yard design solutions, and more specifically with different types of fences, security screens and window:

- front, side and rear fences
- garage doors
- front porches
- balconies
- balustrades
- pergolas
- bike stores
- bin stores
- meters
- window shutters
- security screens.

## References

- Bowler, D. E., Buyung-Ali, L., Knight T. M. & Pullin, A. S. (2010). 'Urban greening to cool towns and cities: a systematic review of the empirical evidence'. *Landscape and Urban Planning*, 97(3), pp. 147–155.
- Bröde, P., Fiala, D., Blazejczyk, K., Epstein, Y., Holmér, I., Jendritzky, G., Kampmann, B., Richards, M., Rintamäki, H., Shitzer, A. & Havenith, G. (2009). 'Calculating UTCI equivalent temperatures'. In: *Environmental Ergonomics XIII, Proceedings of the 13th International Conference on Environmental Ergonomics, Boston, MA, 2–7 August 2009*. Wollongong, NSW: University of Wollongong, pp. 49–53.
- Bröde, P., Krüger, E.L. & Rossi, F.A. (2011). 'Assessment of urban outdoor thermal comfort by the Universal Thermal Climate Index UTCI'. In XIV International Conference on Environmental Ergonomics, Proceedings of the 14th International Conference on Environmental Ergonomics, Nafplio, Greece, 2011, edited by S. Kounalakis & M. Koskolou. Athens, Greece: National and Kapodestrian University of Athens, pp. 338–341.
- Brunner, J. & Cozens, P. (2013). 'Where have all the trees gone? Urban consolidation and the demise of urban vegetation: a case study from Western Australia'. *Planning Practice and Research*, 28(2), pp. 231–255.
- Coutts, A.M., Tapper, N.J., Beringer, J., Loughnan, M. & Demuzere, M. (2013). 'Watering our cities: the capacity for water sensitive urban design to support urban cooling and improve human thermal comfort in the Australian context'. *Progress in Physical Geography: Earth and Environment*, 37(1), pp. 2–28.
- Government of South Australia. (2017). *The 30-year plan for Greater Adelaide – 2017 update*. Adelaide, SA: Department of Planning, Transport and Infrastructure.
- Jackson, W.J., Argent, R.M., Bax, N.J., Bui, E., Clark, G.F., Coleman, S., Cresswell, I.D., Emmerson, K.M., Evans, K., Hibberd, M.F., Johnston, E.L., Keywood, M.D., Klekociuk, A., Mackay, R., Metcalfe, D., Murphy, H., Rankin, A., Smith, D.C., Wienecke, B. (2016). *Overview: Overview*. In: Australia state of the environment 2016. Canberra, ACT: Australian Government Department of the Environment and Energy.
- Jacobson, C.R. (2011). 'Identification and quantification of the hydrological impacts of imperviousness in urban catchment'. *Journal of Environmental Management*, 92(6), pp. 1,438–1,448.
- Lam, K.L., Moravej, M., Renouf M.A. & Kenway, S. J. (2019). *Urban Water Mass Balance (UWMB) tool V1.10*. Melbourne, Victoria: Cooperative Research Centre for Water Sensitive Cities.
- Lindberg, F., Grimmond, C.S., Gabey, A., Huang, B., Kent, C.W., Sun, T., Theeuwes, N.E., Järvi, L., Ward, H.C., Capel-Timms, I., Chang, Y., Jonsson, P., Krave, N., Liu, D., Meyer, D., Olofson, K.F.G., Tan, J., Wästberg, D., Xue, L. & Zhang, Z. (2018). 'Urban Multi-scale Environmental Predictor (UMEP): An integrated tool for city-based climate services'. *Environmental Modelling and Software*, 99, pp. 70–87.
- Murray, S., Bertram, N., Ramirez-Lovering, D., Khor, L. A. & Meyer, B. (2011). *Infill opportunities: design research report*. Melbourne, Victoria: Office of the Victorian Government Architect.
- Newton, P., Newman, P., Glackin, S. & Trubka, R. (2012). 'Greening the greyfields: unlocking the redevelopment potential of the middle suburbs in Australian cities'. *World Academy of Science, Engineering and Technology*, 71, pp. 138–157.
- Newton, P. & Glackin S. (2014). 'Understanding infill: towards new policy and practice for urban regeneration in established suburbs of Australia's cities'. *Urban Policy and Research*, 32(2), pp. 121–143.
- Renouf, M.A., Kenway, S.J., Bertram, N., Sainsbury, O., London, G., Todorovic, T., Pype, M.L., Nice, K. A., Sochacka, B., Moravej, M., Tara, N. & Martin, D. (2019). *Infill Performance Evaluation Framework – DRAFT for consultation*. Melbourne, Victoria: Cooperative Research Centre for Water Sensitive Cities.
- Thomson, G., Newton, P. & Newman, P. (2017). 'Urban regeneration and urban fabrics in Australian cities'. *Journal of Urban Regeneration and Renewal*, 10(2), pp. 169–190.
- Western Australian Planning Commission. (2010). *Directions 2031 and Beyond*. Perth, WA: Department of Planning, Lands and Heritage.
- Wong, T.H.F. & Brown, R.R. (2009). 'The water sensitive city: principles for practice'. *Water Science and Technology*, 60, pp. 637–682.





CRC for  
Water Sensitive Cities

## Cooperative Research Centre for Water Sensitive Cities



Level 1, 8 Scenic Boulevard  
Monash University  
Clayton VIC 3800



[info@crwsc.org.au](mailto:info@crwsc.org.au)



[www.watersensitivecities.org.au](http://www.watersensitivecities.org.au)